

Electronic Exposed TECK® II Flush Valves

(Start-Up from Hibernation Mode)



204265

204265

204265

204265

204265

204265

204265

204265

BATTERY OPERATED FLUSHOMETER

Product No.: 81T2__1-__BT

LESS INLET STOP BATTERY OPERATED FLUSHOMETER

Product No.: 81T2__1-20-__BT

LESS INLET STOP BATTERY OPERATED FLUSHOMETER with modified tail to fit SLOAN®/ZURN® stop

Product No.: 81T2__1-30-__BT

Item #	Part #	Description
1	060329A	Cover Screws and Driver Bit
2	060330A	CP Metal Cover, Screws & Driver Bit
3	060331A	Thumb Screw & O-Ring
4	060357A *	Manual Over-Ride Kit, inc. Metal Button & Rubber Plugs (4/pkg)
5	060539A	Housing Cover, Manual Over-Ride Kit, Thumb Screw & O-Ring
6	060334A	Battery Holder
7	060337A	Cover Screw Hole O-Rings (12/pkg)
8	060078A *	Screws for Cast Cap (4/pkg)
9	061024A	Regulating Screw & O-Ring
10	060340A *	Cover Gasket (6/pkg)
11A	060507A	Water Closet Poppet Pin Pack (3/pkg)
11B	060508A	Urinal Poppet Pin Pack (3/pkg)
12	060779A	Diaphragm/Guide Assembly Complete
13	060182A	RCP Brass Renewable Seat with Gasket
14	060341A	Wrench for Brass Renewable Seat
15	060342A	Plug & O-Ring for Handle End
16	060506A	Standard Adjustable Tail CP
17	060735A	Union Nut CP
18	060692A	Retaining Ring
19	060082A *	Adjustable Tail O-Ring Package (20/pkg)
20	060504A	S/S Wall Flange & Cover Tube
21	061020A	Electronic Water Closet Repair Kit
	061021A	Electronic Urinal Repair Kit
22	060697A	1" Copper Sweat Inlet Adaptor
	060694A	3/4" Copper Sweat Inlet Adaptor
	060764A	3/4" FIP Inlet Adaptor
23	060843A	Retrofit Check Stem Unit, Capnut & Button Complete
	060844A	Seat Washer, Spring, Button & O-Ring Kit
	060859A	Angle Stop with Union Nut & Tail Complete
24	060081A *	Plug Button Package (12/pkg)
25	060785A	VB Sleeve Complete
26	060094A	CP Male Threaded Coupling Ring
27	060782A	1-1/2" x 10" VB, Ring & Tube Complete (for 81T201)
	060783A	1-1/2" x 22-3/4" VB, Ring & Tube Complete (for 81T221)
	060863A	1-1/4" x 10" VB, Ring & Tube Complete (for 81T291)
	060784A	3/4" x 11-1/2" VB, Ring & Tube Complete (for 81T231)
	060781A	1-1/2" x 10" VB, Side Outlet Tee Tube Complete
28	060004A	1-1/2" Spud Flange
	060463A	3/4" CP Coupling Nut, 3/4" Washer & 3/4" Spud Flange
	060745A	1-1/4" Lockring (used with 060004A for 1-1/4" Spud)
29	060778A	1-1/2" Rough Coupling Nut & Washer
	060773A	1-1/4" Rough Coupling Nut & Washer
	060463A	3/4" CP Coupling Nut, 3/4" Washer & 3/4" Spud Flange
30	060083A *	1-1/2" Rubber Slip Joint Washer (12/pkg)
31	060929A	Hardwire Converter with Rigid Connection Assembly
32	060344A	Filter Screen Kit (12/pkg) for Teck tails
	060972A	Filter Screen Kit (6/pkg) for Sloan®/Zurn® tails (-30 models)

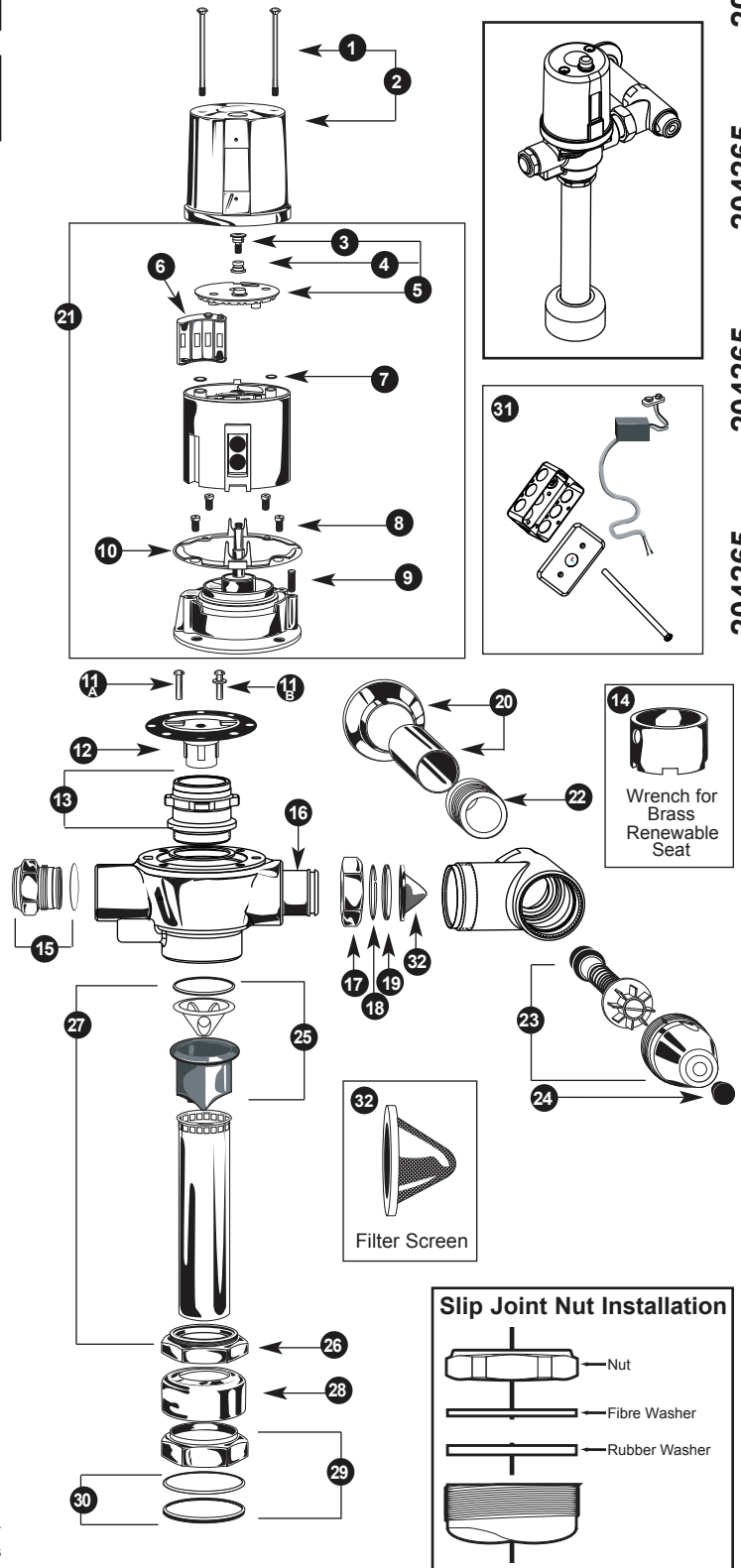

* Package Quantities May Change. Check the parts section of the latest Delta Commercial Faucet Price List for current quantities.

NOTE: Refer to TECK Flushometer Repair Parts and Maintenance Manual for additional parts and information.

PLEASE LEAVE this M&I Sheet with the owner, maintenance plumber, etc. as items relating to ongoing maintenance suggestions and procedures are included.

Product #	A	B	C
	Max.	$\pm 11\text{mm}$ ($7/16"$)	Min.
81T201BT	292mm ($11\frac{1}{2}"$)	121mm ($4\frac{3}{4}"$)	54mm ($2.13"$)
81T201-20BT	292mm ($11\frac{1}{2}"$)	121mm ($4\frac{3}{4}"$)	54mm ($2.13"$)
81T201-6BT	292mm ($11\frac{1}{2}"$)	121mm ($4\frac{3}{4}"$)	54mm ($2.13"$)
81T201-48BT	292mm ($11\frac{1}{2}"$)	121mm ($4\frac{3}{4}"$)	54mm ($2.13"$)
81T201-20-6BT	292mm ($11\frac{1}{2}"$)	121mm ($4\frac{3}{4}"$)	54mm ($2.13"$)
81T231BT	330mm ($13"$)	121mm ($4\frac{3}{4}"$)	54mm ($2.13"$)
81T231-20BT	330mm ($13"$)	121mm ($4\frac{3}{4}"$)	54mm ($2.13"$)

Note: -30 models, B = 114mm - 131 mm (4.5" to 5.18")

BEFORE THE FIRST FLUSH (COMPLETE VALVES)

FLUSH BOTH OLD AND NEW PIPES:

It is important to FLUSH and CLEAN thoroughly both new and old water piping to ELIMINATE contaminants (eg. scale, sediment, gravel, cuttings, solder, etc.) from the line.

Where the water has a sediment content, a PIPE STRAINER in the supply line should alleviate that condition and protect working parts of flushometers and faucets.

On a NEW INSTALLATION, always flush the valve 4 or 5 times to clean out supply line debris. It is also advisable where more than one flushometer is installed on a water line, to flush out the water piping through the last flushometer outlet of the pipe line.

INSTALL FILTER SCREEN (included):

Note: Place filter in stop bore with conical screen facing the water flow.
Caution: Do not push filter in too far. Let filter seat against face of flush valve tail. Periodic cleaning of the filter screen with water is recommended depending on local water conditions to remove any dirt or sediment. See filter screen M&I for additional installation information.

ELIMINATE AIR FROM VALVES:

The FIRST FLUSH should ELIMINATE all air from the TECK flushometer. DO NOT ADJUST flushometer based on the results of the first flush.

TO PREVENT WATER HAMMER:

A capped-pipe vertical AIR CHAMBER may be installed at the last flushometer and/or at the back of an individual installation. This assures SMOOTHER OPERATION of the valves and longer life for the working parts.

HANDS SHOULD BE CLEAN AND FREE OF GREASE AND OIL during any maintenance or handling of electronic housing components to prevent possible damage to internal circuitry.

INSTALLATION INSTRUCTIONS-BATTERY FLUSHOMETER

Step 1:

- Install battery flushometer to fixture.
- Open inlet stop.

If left hand stop is required:

- Remove the chrome cover by taking out the two screws.
- You will now see the electronic compartment with a black cover.
- Loosen the hex screw in the centre of the cover very carefully.
- Now take hold of the compartment and very carefully, slowly turn the compartment 180°.
- The sensor eye should now be on the other side.
- Tighten, being careful not to over-tighten the screw on the cover.
- Replace the chrome cover.

TECK flushometers are individually factory tested and set at 60 psi to:

- 1.60 U.S. gallons/6.0 litres for water closets
- 1.27 U.S. gallons/4.8 litres for water closets
- 0.70 U.S. gallons/2.7 litres for urinal valves

The Regulating Screw (061024A, item #9) may be adjusted, according to job conditions and fixture installed to the proper water volume to flush that particular fixture (except -6 and -48 models which are not field adjustable).

NOTE: 4.8 and 6 Litre water closets or washdown urinals may require the Angle Stop to be set at only ONE TURN OPEN. For a SHORTER flush, turn the Regulating Screw (061024A, item #9) left (counter-clockwise) and right (clockwise) for a LONGER flush (except -6 and -48 models which are not field adjustable).

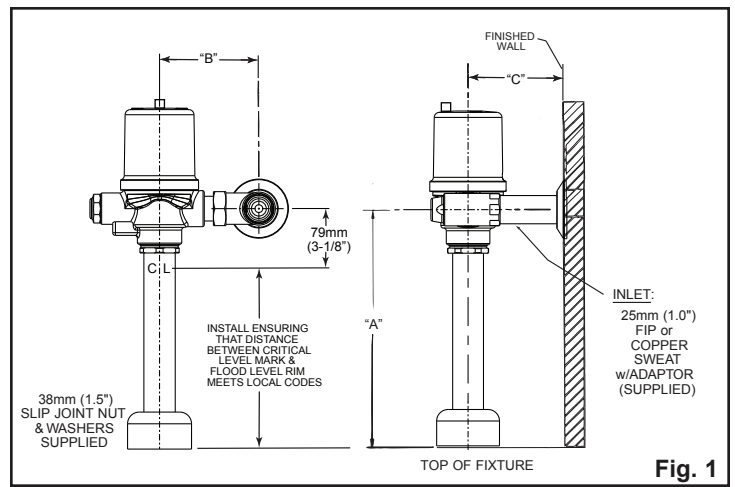

Fig. 1

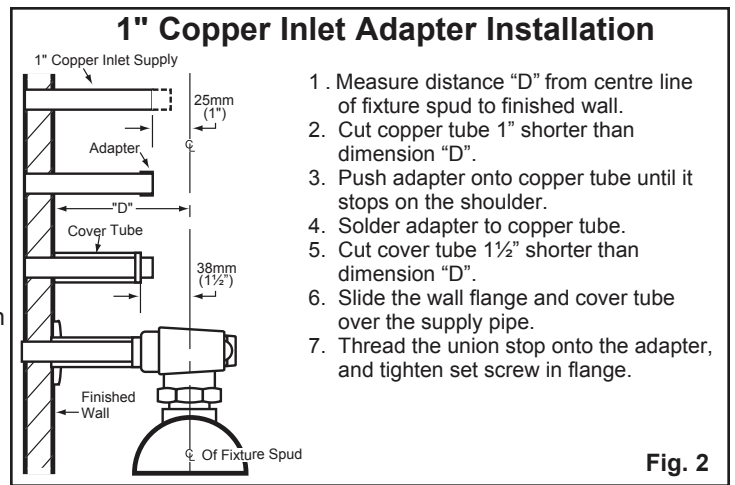

Fig. 2

1. Measure distance "D" from centre line of fixture spud to finished wall.
2. Cut copper tube 1" shorter than dimension "D".
3. Push adapter onto copper tube until it stops on the shoulder.
4. Solder adapter to copper tube.
5. Cut cover tube 1 1/2" shorter than dimension "D".
6. Slide the wall flange and cover tube over the supply pipe.
7. Thread the union stop onto the adapter, and tighten set screw in flange.



Fig. 3

Step 2:

Follow instructions on yellow static label. **Note: The batteries are already installed and the product is in hibernation mode waiting to be activated.** After you remove the yellow label, you must push the manual over-ride button three times within five seconds to activate the valve and to place it into operation mode. To signify the valve has entered operation mode, you will see a red light, a green light and then an amber light sequence.

Step 3: Operation Mode

A sequence of a red, green and then amber light will signify that the valve is in operation mode.

Once in operation mode, if factory settings are preferred, no further action is required and the valve installation is complete.

Factory pre-set functions are:

WC sensing distance of 36", 24 hour flush is off, and flush delay is 3 seconds.
Urinal sensing distance of 24", 24 hour flush is on, and no flush delay.

Once in operation mode, if adjustments are preferred, installer must move into set up mode.

If desired adjustments are not made within 30 minutes, the batteries must be disconnected for 10 seconds and then re-connected to obtain another adjustment period. To make changes, begin at step #4 below.

Step 4: Set-Up Mode (Optional: Only required if factory settings are not preferred.)

- To move from operation mode into set-up mode, push and hold manual override button for five seconds.
- A red and green light will intermittently flash for 3 seconds, 3 times each, to give a total of 18 seconds to select the setting that needs adjustment. If the 18 second window expires with no action, operation mode will resume.
- When the light is red, push the manual override button to adjust sensing distance. (Go to step 5.1)
- When the light is green, push the manual override button to adjust 24 hour flush. (Go to step 5.2)
- To return back into set-up mode, hold override button for 2 seconds.

Step 5: Making Adjustments (Optional: Only required if factory settings are not preferred.)

5.1 Adjusting Sensing Distance:

- Light will be a pulsating green if an object is detected, and each press of the override button shortens sensing distance.
- Light will be a pulsating amber if an object is not detected and each press of the override button increases sensing distance.
- When adjusting sensing distance, light will flash green if sensing distance is at its minimum (WC = 24", Urinal = 18").
- When adjusting sensing distance, light will flash amber if sensing distance is at its maximum (WC = 42", Urinal = 36").
- If light is initially green, the object in front of the sensor is being detected; however, the sensing distance could be set at a distance greater than the desired activating position.
- To ensure sensing distance is set to precise desired position, stand at desired activating distance and press the override button (because the light is green, sensing range will shorten with each press). Continuing to press the override button will decrease the sensing distance back to your position.
- Press override button until light turns from green to amber. The amber light indicates that the sensing distance has been adjusted to a position that is right in front of you, and that the valve's sensor no longer detects you.
- Press the override button one more time (because light is now amber, sensing range will increase with each press.) The light will turn from amber to green, as the sensing distance has now been increased to your exact desired position and you are once again detected by the sensor. The sensor is now set at your desired position.
- If light is initially Amber, the object in front of the sensor is not being detected. Stand at desired activating distance and press the override button (because the light is amber, sensing range will increase with each press). The light will turn green when the sensing distance has been increased to your exact desired position and you are being detected by the sensor.
- The sensing distance for waterclosets can be set between 24" and 42", and for urinals between 18" and 36".
- If further adjustments are desired, move back to set-up mode (Step 4 - alternating red/green light) by holding the override button down for 2 seconds.
- If all adjustments have been completed, no further action is required, and operation mode will automatically resume if the override button is not pressed within 2 minutes.

5.2 Adjusting 24 Hour Flush:

- When the green light single flashes at regular intervals, 24 hour flush is on.
- When the green light double flashes at regular intervals, the 24 hour flush is off.
- Press manual override button to toggle between on and off mode.
- If further adjustments are desired, move back to set-up mode (Step 4 - alternating red/green light) by holding the override button down for 2 seconds.
- If all adjustments have been completed, no further action is required, and operation mode will automatically resume if the override button is not pressed within 2 minutes.

*** After the last adjustment has been completed and the flush valve has returned to operation mode, there is a window of approximately 30 minutes where additional changes can be made.**

If desired adjustments are not made within 30 minutes, the batteries must be disconnected for 10 seconds and then re-connected to obtain another adjustment period. To make changes, begin at step #4 above.

FUNCTION AND TROUBLESHOOTING LIGHTS:

NO LIGHTS-NO POWER

Check that the 4 AA batteries are positioned properly in the battery holder. Use the slotted outline of the battery in the battery holder and/or the +/- on the battery holder for correct positioning.

If the batteries are positioned correctly but there are still no lights, replace with 4 new AA Alkaline batteries. (See Battery Replacement below).

BATTERY REPLACEMENT

1. Remove the two cover screws and lift off CP metal cover (060330A, item #2). Remove the thumbscrew and plastic cover from top of the electronics housing. (Refer to Fig. 4)
2. Remove the battery pack from electronic housing and discard depleted batteries.
3. Insert new set of four AA batteries into battery holder. (Use the slotted outlines on the battery holder and/or the +/- signs on the battery holder for correct positioning.)
4. Install the refreshed battery holder into the electronic housing. (When the new batteries are installed and connected, an initial one-time red, green, and then amber light sequence will occur.)
5. Re-assemble plastic housing cover to the electronic housing with thumbscrew. Test the manual override button. Amber light flashes once when override is activated.
6. Place the CP metal cover (060330A, item #2) back onto flushometer and hold in place with the two cover screws. Flushometer is now ready for use.

* **Note:** All original settings will be retained when batteries are changed.

1. **Start-Up:** When batteries are first inserted, there is an initial one-time light sequence of RED then GREEN then an AMBER light.
2. **Override Button in Operating Mode:** AMBER light flashes once when Override Button is activated. Should the manual override button stick, the program will continue to operate and will reset automatically if the override button is repaired or it returns to home position.
3. **Battery Level Indicator:** RED light flashes every 15 seconds, indicating approximately 5,000 flushes remain from when RED light first started flashing.

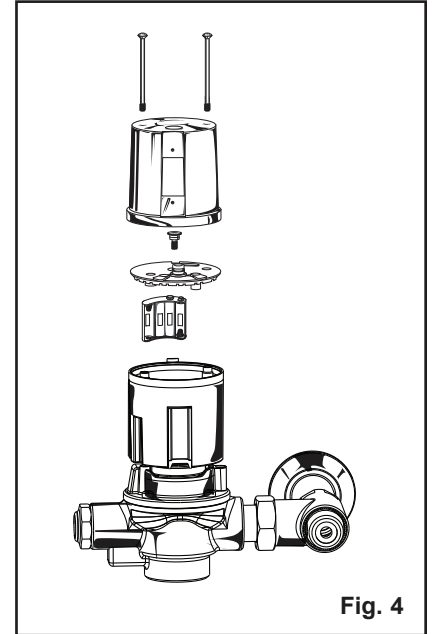

PROBLEM SOLVING & MAINTENANCE SUGGESTIONS:

NOTE: DO NOT USE EXCESSIVE FORCE to close the inlet stop stem. We RECOMMEND that the flushometer be flushed while closing the inlet stop. The noise created by the water flow or the flow into the fixture will stop when the inlet water is shut off.

NOTE: Always use DELTA COMMERCIAL GENUINE PARTS to maintain the warranty.

EXCESSIVE NOISE:

1. PARTIALLY close the inlet stop.
2. Pressures OVER 75 PSI may lead to an increase in NOISE, water could SPLASH out of the fixture more easily and the LIFE of any plumbing valve may be SHORTENED.
3. INSTALL a Pressure Reducing Valve set at a lower pressure if actual pressure is over 75 PSI. While the TECK Flushometer will operate up to 125 PSI, the preferred operating range is between 35 to 65 PSI.
4. On flushometers that have been installed for a number of years, check the Renewable Seat (060182A, item #13) for wear and replace if necessary.

EXCESSIVE WATER FLOW RATE:

1. OPEN inlet stop ONE TURN and adjust Regulating Screw (061024A, item #9) to the fixture requirement (except on -6 and -48 models which are fixed volume).
2. Operation of flushometer with inlet stop BELOW ONE TURN OPEN may cause EXCESSIVE NOISE. The lowest open setting for the inlet stop may vary dependent on the installation.

SHORTAGE OF WATER TO PROPERLY FLUSH BOWL:

1. OPEN inlet stop fully.
2. CHECK pipeline for size or obstruction, partially closed gate or other supply line valve, corroded or undersize water piping.
3. CHECK water pressure.
4. Water flow rate is determined by BOTH the water pipe size AND the water pressure available.
5. A water closet flush valve requires a minimum water supply of 1" (or larger), depending on a number of different factors including water pressure (PSI) available, pipe size and length of pipe run, number of fixtures per washroom and per building, fixture type, fixture usage factor, elevation of valve above the water main, etc. We strongly recommend that pipe size calculations be done to insure proper water supply sizes. A Piping Calculation Guide is available on request.

Flushometers do NOT provide a water supply; they are merely automatically timed self-closing valves. The inlet supply piping is the water reservoir that must supply sufficient water volume in a short period of time (4 to 10 seconds) to properly flush and clear the fixture.

CONTINUOUS FLUSHING:

1. The Regulating Screw (061024A, item #9) may be turned RIGHT (clockwise) TOO FAR. Adjust by slowly turning the Regulating Screw LEFT (counter-clockwise). (Except -6 and -48 models which are fixed volume).
2. If flush is still continuous, remove 061024A Regulating Screw, CLEAN bypass slot in the Screw, REPLACE it in the valve and ADJUST slowly for proper flush (except -6 and -48 models which are fixed volume).
3. Remove cast cap assembly and Diaphragm/Guide Assembly (060779A, item #12), check for contaminants at renewable seat and diaphragm and check for debris in the cap for blockage. Also CHECK that the Diaphragm/Guide slides easily in the Renewable Seat.
4. After replacing the Diaphragm, be sure the sintered bronze Valve Silencer and the flat, white Plastic Washer are correctly aligned with the Cast Guide and do not catch on the top of the Renewable Seat (060182A, item #13). To assure PROPER ALIGNMENT, slide the Diaphragm/Guide Assembly (060779A, item #12) into the Renewable Seat until the Diaphragm/Guide slides and seats smoothly and easily.

VALVE WILL NOT FLUSH:

1. When the valve has been taken apart for servicing and re-assembled and does NOT operate, check that the Cast Cap has been put on the body properly. The Regulating Screw (061024A, item #9) should always be on the same side as the inlet stop.
2. When all lights operate as expected but valve will not flush, check that the solenoid makes a clicking sound. If no clicking sound is present, then replace with Electronic Repair Kit (WC - 061020A or UR - 061021A, item #21).
3. After a number of years, the valve will flush but shuts off immediately when activated. The Diaphragm (060779A, item #12) is worn or split and needs replacing.

SLIGHT WATER LEAK INTO FIXTURE:

1. EXAMINE the seating surface of the Diaphragm Seat (060779A, item #12) for imbedded sediment.

CLEANING INSTRUCTIONS:

CLEAN the outside of the chrome plated flushometer with a damp cloth.

CAUTION: MOST Tub & Tile fixture cleaners contain ACIDS. DO NOT WIPE the cloth used to clean ceramic fixtures over the flushometer as it will remove the chrome plating and leave a discoloured surface.

For a copy of the "TECK Flushometer Maintenance Manual/Piping Calculation Guide", contact your local Delta Representative.

APPROVALS:

CSA Certified.
ADA Compliant.
IAPMO Listed.
Complies to ASSE 1037.

Delta Commercial Faucet Limited Warranty

All parts of the Delta® HDF® and TECK® faucets are warranted to the original consumer purchaser to be free from defects in material, finish and workmanship for a period of five (5) years unless otherwise specifically stated in the catalogue and price book. This warranty is made to the original consumer purchaser and shall be effective from date of purchase as shown on purchaser's receipt.

Delta will, at its option, repair or replace, FREE OF CHARGE, during the warranty period, any part which proves defective in material or workmanship under normal installation, use and water and service conditions. If Delta Faucet concludes that the returned part was manufactured by Delta Faucet and is, in fact, defective, then Delta Faucet will honour the warranty stated herein. Replacement parts can be obtained from your local dealer or distributor listed in the telephone directory or by returning the part along with the purchaser's receipt to our factory, TRANSPORTATION CHARGES PREPAID, at the address listed. THIS WARRANTY IS THE ONLY EXPRESS WARRANTY MADE BY DELTA. ANY CLAIMS MADE UNDER THIS WARRANTY MUST BE MADE DURING THE FIVE YEAR PERIOD REFERRED TO ABOVE. ANY IMPLIED WARRANTIES, INCLUDING THE IMPLIED WARRANTY OF MERCHANTABILITY OF FITNESS FOR A PARTICULAR PURPOSE, ARE LIMITED IN DURATION TO THE DURATION OF THIS WARRANTY. LABOUR CHARGES AND/OR DAMAGE INCURRED IN INSTALLATION, REPAIR OR REPLACEMENT AS WELL AS INCIDENTAL AND CONSEQUENTIAL, SPECIAL, INDIRECT OR PUNITIVE DAMAGES CONNECTED THEREWITH ARE EXCLUDED AND WILL NOT BE PAID BY DELTA FAUCET.

Some states do not allow limitations on how long an implied warranty lasts, or the exclusion or limitation of incidental or consequential damages, so the above limitations or exclusions may not apply to you. This warranty gives you specific legal rights, and you may also have other rights which vary from state to state.

This warranty is for commercial products only from Delta Faucet Company and Delta Faucet Canada (a division of Masco Canada Limited) and is void for any damage to this faucet due to misuse, abuse, neglect, accident, improper installation, any use in violation of instructions furnished by Delta Faucet or any use of replacement parts other than genuine Delta parts.

Garantía Limitada de las Llaves de Agua Comerciales Delta

Todas las piezas de las llaves de agua (grifos) Delta® HDF®, TECK® están garantizadas al comprador consumidor original de estar libres de defectos de material, acabado y fabricación por un periodo de cinco (5) años a menos que sea establecido específicamente de otra manera en el catálogo o libro de precios. Esta garantía se le hace al comprador consumidor original y será efectiva desde la fecha de compra como mostrado en el recibo del comprador.

Delta, a su opción, reparará o reemplazará, GRATUITAMENTE, durante el periodo de garantía, cualquier pieza que pruebe ser defectuosa en material o fabricación bajo instalación, usu, agua y condiciones de servicio normales. Si Delta Faucet concluye que la pieza devuelta fue fabricada por Delta Faucet y es, de hecho, defectuosa, entonces Delta Faucet honrará la garantía establecida en este documento.

Las piezas de repuesto se pueden obtener de su comerciante o distribuidor local listado en el libreto telefónico o devolviendo la pieza junto con el recibo del comprador a nuestra fábrica, CARGOS DE TRANSPORTE PRE-PAGADOS, a la dirección incluida. ESTA GARANTÍA ES LA ÚNICA GARANTÍA EXPRESA HECHA POR DELTA. CUALQUIER RECLAMO HECHO BAJO ESTA GARANTÍA DEBE SER HECHO DURANTE EL PERÍODO DE CINCO AÑOS ARRIBA MENCIONADO. CUALQUIER GARANTÍA IMPLÍCITA, INCLUYENDO LA GARANTÍA IMPLÍCITA DE COMERCIABILIDAD DE EMPLEO PARA UN PROPÓSITO PARTICULAR, TIENE UNA DURACIÓN LIMITADA A LA DURACIÓN DE ESTA GARANTÍA. LOS CARGOS DE LABOR Y/O DAÑO INCURRIDO DURANTE LA INSTALACIÓN, REPARACIÓN O REPUESTO COMO TAMBIÉN DAÑOS INCIDENTALES O RESULTANTES, ESPECIALES, INDIRECTOS O PUNITIVOS RELACIONADOS CON LO MENCIONADO SON EXCLUIDOS Y NO SERÁN PAGADOS POR DELTA FAUCET.

Algunos estados no permiten limitaciones de la duración de una garantía implícita limitada, o la exclusión o limitación de daños incidentales o consecuentes, de manera que las limitaciones o exclusiones arriba mencionadas puedan no aplicarle a usted. Esta garantía le da derechos legales específicos, y usted también puede tener otros derechos que varían de estado a estado.

Esta garantía es solo para productos comerciales de Delta Faucet Company y Delta Faucet Canada, una división de Masco Canada Limitada, y es nula por cualquier daño hecho a esta llave de agua resultante del mal uso, abuso, descuido, accidente, instalación incorrecta, cualquier uso en violación de las instrucciones proporcionadas por Delta Faucet o cualquier uso de piezas de repuesto que no sean de piezas genuinas de Delta.

Garantie Limitée Delta Commercial

Toutes les pièces des robinets de marque Delta® HDF® et TECK® sont garanties contre tout défaut de matière, de finition et de main-d'oeuvre pour une période de cinq (5) ans, sauf indication contraire stipulée dans le catalogue et la liste des prix. Cette garantie est offerte à l'acheteur original et entre en vigueur à compter de la date d'achat indiquée sur la preuve d'achat.

Delta procédera, à son entière discrétion, à la réparation ou au remplacement, SANS FRAIS, durant la période de garantie, de toute pièce qui présente un défaut de matière ou de main-d'oeuvre dans des conditions d'installation, d'usage, d'eau et de service normales. Si Delta Faucet détermine que la pièce retournée a été fabriquée par Delta Faucet et qu'en effet, cette pièce fait défaut, Delta Faucet respectera alors la garantie stipulée aux présentes. Les pièces de rechange peuvent être obtenues chez votre marchand local ou le distributeur inscrit dans votre annuaire téléphonique, ou en retournant la pièce ainsi que la preuve d'achat à notre usine, FRAIS DE TRANSPORT PRÉPAYÉS, à l'adresse indiquée. CETTE GARANTIE EST LA SEULE GARANTIE EXPRESSE FAITE PAR DELTA.

TOUTE RÉCLAMATION FAITE EN VERTU DE CETTE GARANTIE DOIT ÊTRE PRÉSENTÉE DURANT LA PÉRIODE DE CINQ ANS MENTIONÉE CI-DESSUS. TOUTE GARANTIE IMPLICITE, Y COMPRIS LA GARANTIE IMPLICITE DE VALEUR COMMERCIALE RELATIVEMENT À L'APTITUDE À LA FONCTION, EST LIMITÉE EN TERMES DE DURÉE POUR LA DURÉE DE CETTE GARANTIE.

LES FRAIS DE MAIN-D'OEUVRE ET/OU DE DOMMAGES ENCOURUS DURANT L'INSTALLATION, LA RÉPARATION OU LE REMPLACEMENT AINSI QUE LES DOMMAGES-INTÉRÊTS ACCESSOIRES OU IMMATÉRIELS, SPÉCIAUX, INDIRECTS OU PUNITIFS S'Y RAPPORTANT SONT EXCLUS ET NE SERONT PAS PAYÉS PAR DELTA FAUCET.

Certains états ne permettent pas la limitation de la durée de la garantie implicite, ou l'exclusion ou la limitation des dommages-intérêts accessoires ou immatériels, et par conséquent, les limitations ou les exclusions stipulées ci-dessus peuvent ne pas s'appliquer dans votre cas. Cette garantie vous accorde certains droits reconnus par la loi et vous avez peut-être aussi d'autres droits qui varient d'un état à l'autre.

Cette garantie s'applique seulement aux produits commerciaux des sociétés Delta Faucet et Delta Faucet Canada, une filiale de Masco Canada Limited et est nulle de plein droit pour tout dommage causé à ce robinet en raison d'usage excessif, d'abus, de négligence, d'accident, de mauvaise installation, tout usage en contravention des directives fournies par Delta Faucet ou tout usage de pièces de rechange autres que des pièces originales Delta.

Delta Faucet Canada, a division of Masco Canada Limited
Box 5750, 420 Burbrook Place, London, ON, Canada N6A 4L6
1-800-567-3300 (English) 1-800-265-9245 (French)

Delta Faucet Company
Box 40980, 55 East 111th St., Indianapolis, IN, U.S.A. 46280
(317) 848-1812

For further technical assistance, call Delta Commercial Technical Service at 1-800-387-8277.

Para la asistencia técnica adicional, servicio técnico Comercial del Delta de la llamada en 1-800-387-8277.

Pour obtenir de l'assistance technique, appelez le Service Technique de Delta Commercial au 1-800-387-8277.