

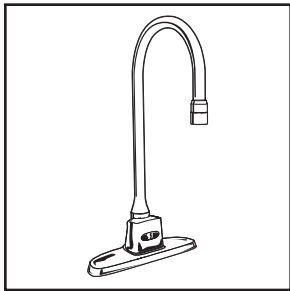

300__T__ __ __ __ __A

Write purchase model number here for future reference

NOTE: For optimum performance of this product, we recommend a system pressure between 20 and 80 PSI static. This product will operate up to a maximum of 125 PSI static per ANSI and CSA requirements. However, we do not recommend pressure above 80 PSI. Thermal expansion or leaking pressure reducing valves may require the use of expansion tanks or relief valves to ensure your system never exceeds its maximum intended pressure setting.



205716

205716

205716

205716

205716

205716

205716

205716

205716

205716

060977A (R3)
060979A (R4)
060904A (R5)
060981A (R7)
060982A (R35)
 Single-Hole Mount Assembly including Sensor and Hold-Down Package and Spout (with smooth ends)

060637A
 VR laminar outlet with Agion® Antimicrobial
060639A
 VR Flow Control Aerator & Wrench

060976A (R3)
060978A (R4)
060903A (R5)
060980A (R7)
061008A (R35)
 Single-Hole Mount Assembly including Sensor and Hold-Down Package and Spout with aerator thread

060564A
 Single Hole Deck Gasket (6/pkg)

060564A
 Single Hole Deck Gasket (6/pkg)

060546A
 4" Deck Plate & Hold-Down Package

RP6087
 Nut & Washer

060547A
 8" Deck Plate & Hold-Down Package

061056A
 0.5 USGPM (1.9 L/min)
062020A
 1.5 USGPM (5.7 L/min)
 Adapter with Flow Control for smooth end spouts

RP6092
 Deck Plate Nut & Washer

OPTION LIST

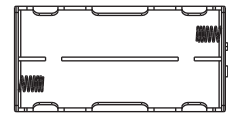

060681A
 Battery Holder



060571A
 Mounting Hardware

TRANSFORMERS

- 060704A**
Transformer 110 to 24 VAC 20VA up to 5 Electronic Valves
- 060771A**
Transformer 110 to 24 VAC 40VA up to 10 Electronic Valves
- 060772A**
Transformer 110 to 24 VAC 100VA up to 25 Electronic Valves

DECK PLATES

- 060548A**
4" Deck Plate Gasket (6/pkg)
- 060546A**
4" Deck Plate & Hold-Down Pkg
- 060549A**
8" Deck Plate Gasket (6/pkg)
- 060547A**
8" Deck Plate & Hold-Down Pkg

Note: See page 3 for parts breakdown on recessed & surface mount boxes.

OR

060905A
 Cover Gasket

060906A
 Surface Mount Housing

060989A
 Controller

060910A
 Solenoid Valve with 3/8" Compression Connectors

060908A
 Solenoid Holder

060909A
 Screen Assembly

060913A
 3/8" Comp Connect Nut and Ferrile

060690A
 36" Cable Extension

060416A
 Bypass Adaptor

RP30523
 Braided Hose

060683A
 24VAC to 6VDC Converter

*Package Quantities May Change.
 Check the Parts section of the latest Delta Commercial Faucet Price List for current quantities.

PLEASE LEAVE this M&I Sheet with the owner, maintenance plumber, etc. as items relating to ongoing maintenance suggestions and procedures are included.

Installation should be in accordance with local plumbing and electrical codes.
FLUSH ALL PIPES THOROUGHLY BEFORE INSTALLATION.

INSTALLATION AND SET UP INSTRUCTIONS

FOR SURFACE MOUNT HOUSING: CONTROL BOX #0

STEP 1. FAUCET INSTALLATION

Connect 20" braided hose to spout inlet. Clean deck/sink surface where faucet will be mounted. Mount faucet to sink using nut(s) and washer(s) provided. Installation of the single hole deck gasket (060564A) between the turret base and mounting surface is the recommended assembly practice. Ensure that gasket is sitting flat on the deck and the turret is centered on the gasket. Use the same procedure for installation of optional 4" or 8" deck plate package (060546A or 060547A). Mount the faucet to the sink using nut(s) and washer(s) provided. Do not overtighten the nut (RP6087) or reposition the turret once installed, otherwise damage to the gasket may result. Cutting or trimming of the gasket is not recommended. **NOTE: If the gasket is trimmed or not installed, then use clear silicone sealant between the faucet and lavatory to prevent water from leaking beneath lavatory.**

STEP 2. BATTERY BOX INSTALLATION

Mount battery box to wall under sink using the 4 supplied screws and anchors. Use a 1/4" drill for wall anchors. **Be sure to install the box within the dimensions provided so the hose and spout cable will reach connections at faucet and battery box.** Refer to illustration (Fig. 2).

STEP 3. FLUSH SYSTEM

To flush supply line, assemble these components as shown (Fig. 3) and run water for 1 minute. Shut off water supply. Attach aerator. **NOTE: Do not connect supply to the solenoid inlet until line is flushed directly out spout.**

STEP 4. CONNECT WATER SUPPLY

Disassemble the components, reassemble the ones shown here (Fig. 4) supply line and adaptor to the bottom fitting on box, braided hose to the top fitting on box. Use plumber tape where indicated on adaptor. Turn on water supply. **DO NOT SOLDER CONNECTIONS!**

STEP 5. POWER UP

Unscrew the battery box lid screws (2). Install 4 "C" batteries in holder or snap the battery clip directly to the optional 24 VAC converter.

⚠ BATTERY VERSION Use caution not to damage wires or components on electronic controller. Install four "C" batteries provided into the battery holder. After the batteries are installed, make the sensor connection on the controller neatly inside the battery box. Connect battery clip to battery pack. The blue backlit LCD screen will power up and the battery strength screen will appear. See Fig 5. Secure lid using screws.

⚠ HARDWARE VERSION Install CSA and/or UL approved Class 2 transformer or equivalent in a convenient location or in a pipe chase. **(Do NOT install the transformer inside the control box.)** With the power off, bring the 24 VAC supply wires to the box. Connect the 24 VAC supply to the 060683A conversion kit. Connect the battery snap of the hardware converter to the controller battery clip. Ensure snap does not touch any conductive metal surface. Turn on power supply for the transformer and then make the sensor connection on the control module neatly inside the battery box.

STEP 6. PREPARE SINK AREA

Before connecting the spout cable – clean off counter and remove all objects from the sink.

STEP 7. TIE SPOUT CABLE

Attach spout cable to box connector. Use tie wraps to secure spout cable to spout hose. Your faucet is now ready for use (Fig. 2).

STEP 8. TEST FOR OPERATION

Test for operation. If faucet leaks from spout outlet: SHUT OFF WATER SUPPLIES. Replace Battery Box Assembly (1).

If faucet exhibits very low flow: A) Remove and clean spray outlet, or B) SHUT OFF WATER SUPPLY. Clean or replace screen assembly (2). If unit does not work properly, see Trouble Shooting Guide on page 5.

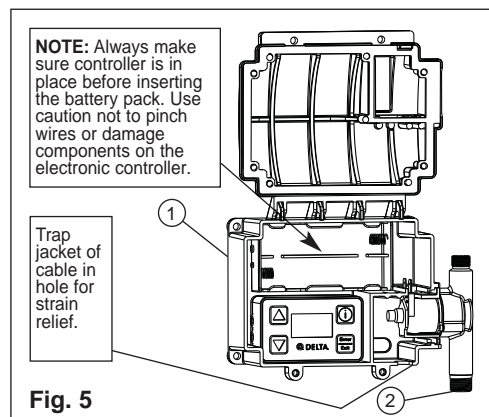
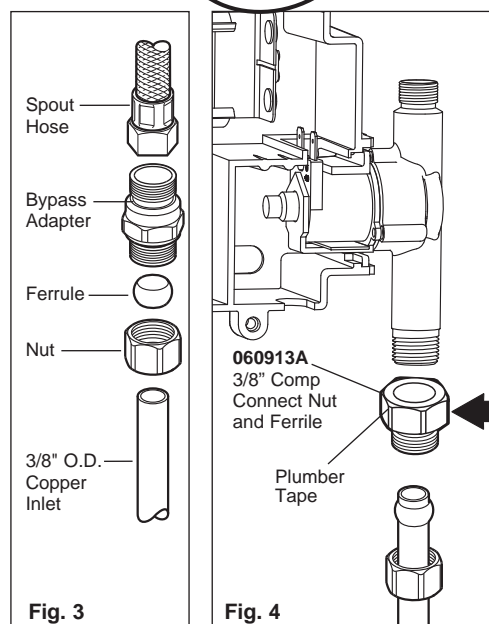
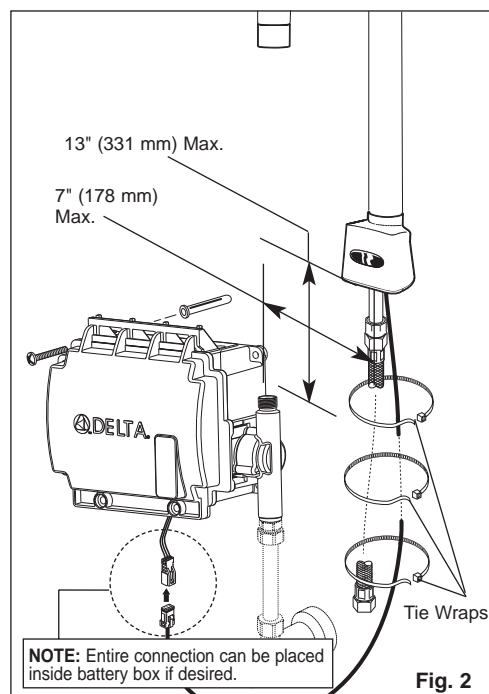

Installation should be in accordance with local plumbing and electrical codes.
FLUSH ALL PIPES THOROUGHLY BEFORE INSTALLATION.

INSTALLATION AND SET UP INSTRUCTIONS

FOR 10" BOXES

STEP 1. ROUGH IN

HARDWARE Remove suitable knockout(s) in box(es) and insert cable bushing(s). See Fig. 6.

Note: Wires connecting between box(es) and from transformer must be protected from abrasion, and being pulled at connections. They also may have to be fished through at a later stage of construction. Depending on installation, the cable bushings included may be replaced by installer supplied 1/2" conduit. Rough-in box as per Fig. 10a.

The transformer is to be installed in an adjacent accessible space. **(Do NOT install the transformer inside the control box.)** Cable from the transformer to the controller may be roughed in at this time depending on installation. Use cable which complies to local electrical codes for 1 amp load. No. 18 is usually sufficient.

HARDWARE OR BATTERY If recessed box is supplied, rough in as per Fig. 10a. The most vandal resistant installation is when the control box is as close to the bottom of the sink as feasible. For wall hung sink installation, sensor conduit rough in should be directly under the basin to minimize sensor cord exposure. Rough in drainage. Rough in water supply to 10" control box inlets and to spout connection. Finish walls. If surface mount box as per Fig. 10b is supplied, attach to wall.

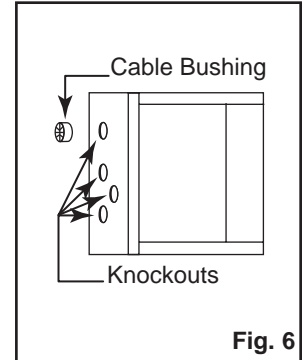

Fig. 6

STEP 2. FAUCET INSTALLATION

Connect 20" braided hose to spout inlet. Clean deck/sink surface where faucet will be mounted. Mount faucet to sink using nut(s) and washer(s) provided. Installation of the single hole deck gasket (060564A) between the turret base and mounting surface is the recommended assembly practice. Ensure that gasket is sitting flat on the deck and the turret is centered on the gasket. Use the same procedure for installation of optional 4" or 8" deck plate package (060546A or 060547A). Mount the faucet to the sink using nut(s) and washer(s) provided. Do not overtighten the nut (RP6087) or reposition the turret once installed, otherwise damage to the gasket may result. Cutting or trimming of the gasket is not recommended. **NOTE: If the gasket is trimmed or not installed, then use clear silicone sealant between the faucet and lavatory to prevent water from leaking beneath lavatory.**

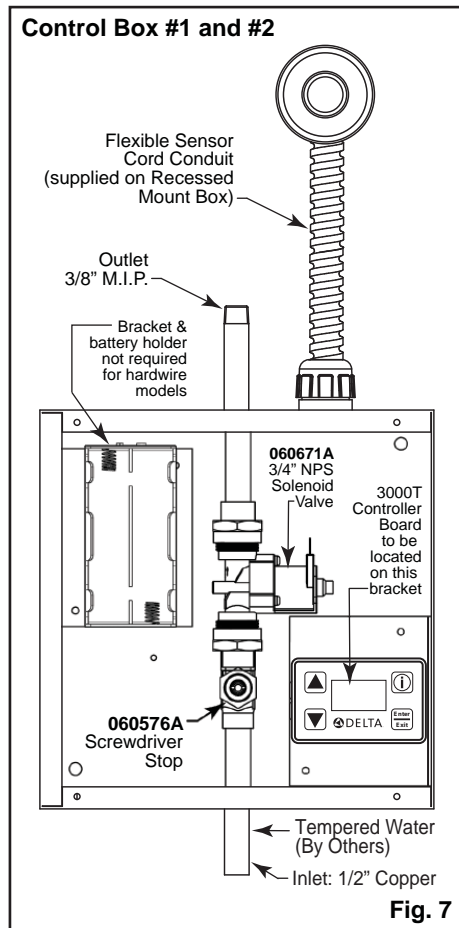

Fig. 7

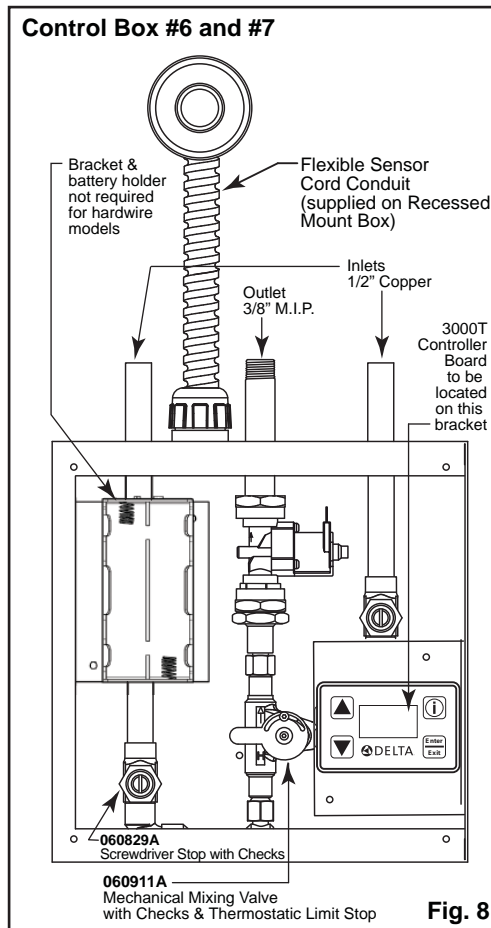

Fig. 8

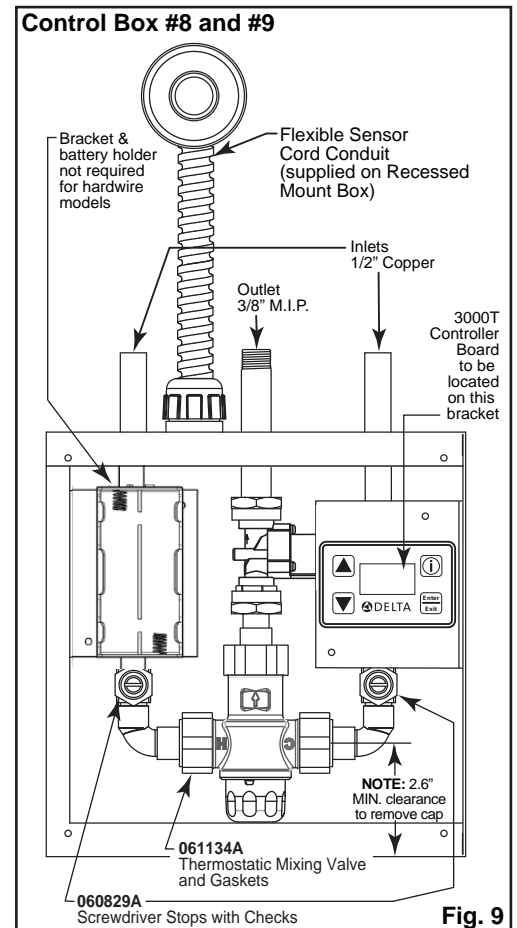
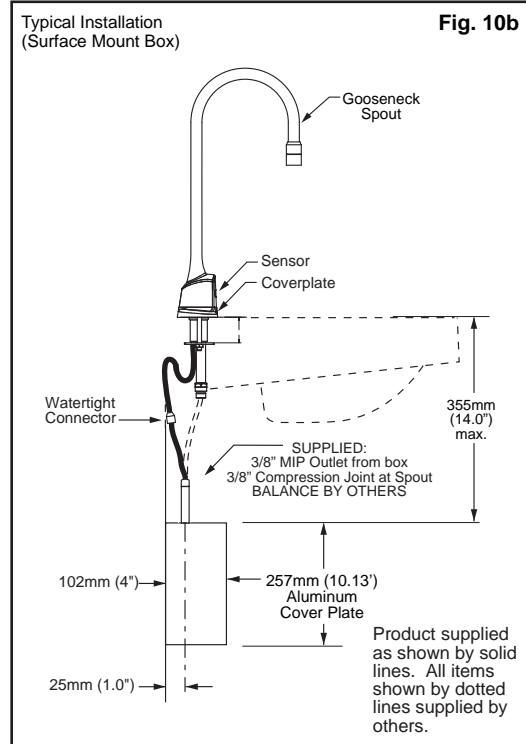
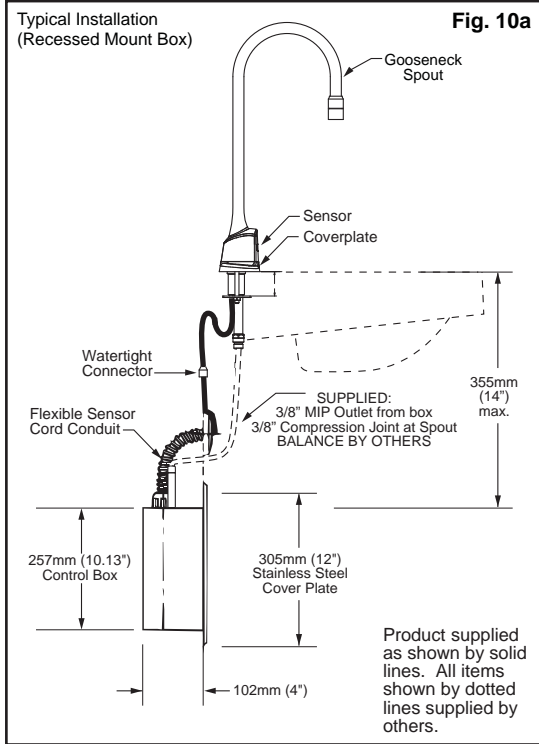

Fig. 9

COVERS		TMV Repair Kits	
060578A 10" Aluminum Cover	060577A 12" Stainless Steel Cover	060073A Screws (4/pkg) & driver bit for covers	061135A Gasket Kit only (3 pcs)
			061137A Adjustment Wrench

INSTALLATION AND SET UP INSTRUCTIONS

FOR 10" BOXES



STEP 3. CONNECT WATER SUPPLY

Install sink and connect drainage to rough in. See applicable Fig. 7, Fig. 8 or Fig. 9. Please note that the connection tube and fittings are supplied by the installer to connect the 3/8" MIP at the box outlet and compression joint for 3/8" O.D. Soft copper tube at the spout. Connect water supply through to spout. Assure supply lines are completely flushed and free of debris.

STEP 4. FLUSH SYSTEM/SET TEMPERATURE

Remove coverplate from control box. Open screwdriver stop(s) to flush installation for **1 minute minimum**.

- 4A** Run water for a sufficient time so the hot and cold water supplies are as hot and cold as they will get.
- 4B** Place a thermometer in a plastic container and hold in the water stream. Record the temperature reading and note position of temperature control, and lock at the desired setting.
- 4C** If **Mechanical Mixing Valve** (060911A) (Fig. 8). Adjust setting to the desired temperature and lock in place by tightening the vandal resistant screw.

If **Thermostatic Mixing Valve** (Fig. 9). To adjust the mixed outlet temperature of the valve, remove the cap to gain access to the adjusting spindle. The spindle should be rotated towards the "C" side to reduce the temperature and towards the "H" side to increase the temperature - until the desired set point is reached (refer to Fig.11).

Periodic Inspection/Maintenance - We recommend that this valve is checked at least once per year to ensure its continued function. For installations with poor or unknown water quality, or other adverse supply conditions, it may be necessary to check the valve at more frequent intervals. The temperature should be checked at the same outlet as was used for commissioning in the first instance. If the temperature is more than 3°F from the commissioning in temperature, refer to the included Cash Acme Maintenance and Installation Guide.

- 4D** Close stops.

STEP 5. CONNECT ELECTRICAL SUPPLY, SOLENOID VALVE AND SENSOR

Remove plastic threaded spacer nipple and install solenoid valve with body arrow in the direction of water flow. See Fig. 12. Feed sensor wire from spout into control box and then into the battery holder. Connect red solenoid cord to "+" marked solenoid terminal on solenoid valve, black solenoid cord to other solenoid terminal.

- ⚠ BATTERY VERSION** Use caution not to damage wires or components on electronic controller. Remove cover from control box and install four "C" batteries provided into the battery holder. After the batteries are installed, make the sensor connection on the controller neatly inside the battery box. Ensure snap does not touch any conductive metal surface. Connect battery clip to battery pack. The blue backlit LCD screen will power up and the battery strength screen will appear. See Fig. 13. Secure lid using screws.

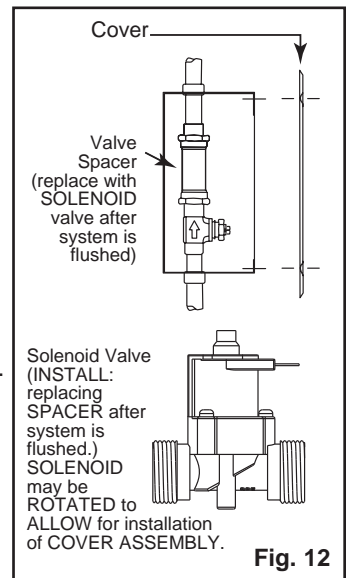
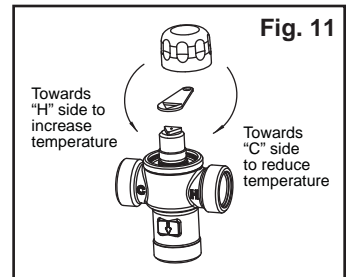

INSTALLATION AND SET UP INSTRUCTIONS

FOR 10" BOXES

STEP 5. CONNECT ELEC SUPPLY, VALVE & SENSOR (CONT'D)

HARDWARE VERSION Install CSA and/or UL approved Class 2 transformer or equivalent in a convenient location or in a pipe chase. **(Do NOT install the transformer inside the control box.)** With the power off, bring the 24 VAC supply wires to the box. Connect the 24 VAC supply to the 060683A conversion kit, (see page 1). Connect the battery clip of the hardwire converter to the controller battery clip. Ensure snap does not touch any conductive metal surface. Turn on power supply for the transformer and then make the sensor connection on the control module neatly inside the battery box.

STEP 6. SERVICES

Open screwdriver stop(s). Flush line. Install aerator.

STEP 7. TEST FOR OPERATION

Test for operation. If unit does not work properly, see Troubleshooting Guide on page 7.

STEP 8. MAKING ADJUSTMENTS

If adjustments are required. Note factory defaults for program shown in Quick Reference Chart. Otherwise, replace the driver board housing cover as the electronic product is ready for use.

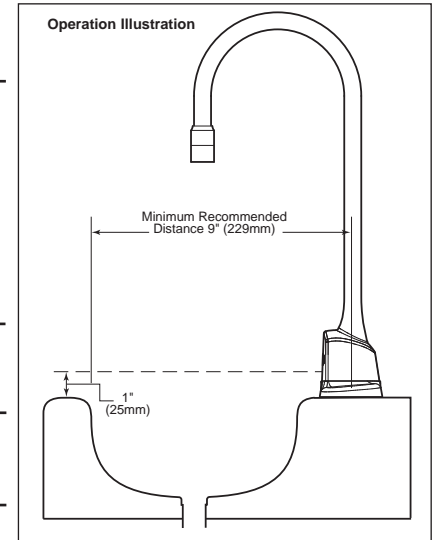

3000TA CONTROLLER QUICK REFERENCE CHART

Selection Adjustment	Description	Factory Default Setting	Adjustment Range
Run-On time	The length of time water will run after the user removes their hands from the sensing zone.	0 Seconds	0 to 8 seconds and then 1 minute to 8 minutes
Response Time	Response Time is the amount of time it takes for the sensor to react to hands placed in the sensing zone.	Standard (4 pulses/second)	3 Settings: Fast (8 pulses/second) Standard (4 pulses/second) Slow (2 pulses/second)
Block Time	The amount of time required between uses. This prevents the faucet from running water excessively.	1 second	1 to 8 seconds of blocking time
Sensor Range	You can set the distance at which the sensor will detect hands in the wash area.	10" from sensor	3" to 15" from sensor
Auto Timer	The auto timer is the length of time before the faucet stops running in the event that the sensor is obstructed by a foreign object.	1 minute + Run-On time	Not Adjustable
Metering Mode	Allows for continuous flow for a set amount of time, regardless of how long an object is placed in front of the sensor. Run-On settings are disabled in this mode.	Disabled	7 to 240 seconds (if enabled)

Making Adjustments - Controller Interface

UP and DOWN arrows

These arrows are used to navigate up and down. Use these arrows to highlight the feature you wish to adjust, as well as selecting the desired adjustment value.

LCD screen

Provides visual feedback of the functions and settings of the 3000TA controller.

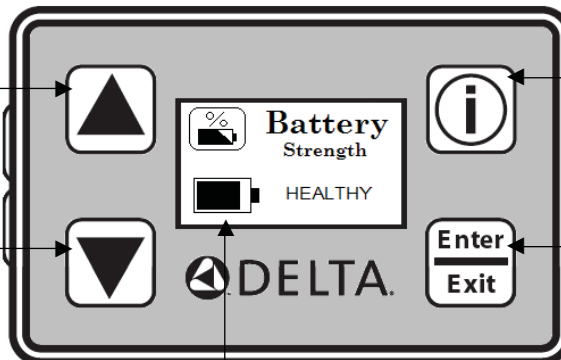

Info Icon

Press this button at any time to display information about the highlighted item or adjustable feature. To exit the information screen, press the Enter/Exit button.

Enter/Exit Button

Use this button to enter an adjustment feature (i.e. Sense Time, Run-On Time) found in the main menu, as well as to make the desired adjustments to that feature. To exit, press the Enter/Exit button again.

Fig. 13

STEP 9. SETTING THE CONTROLLER

(If adjustments are required. Note factory defaults for program shown in Quick Reference Chart.)

Press the Enter/Exit button on the controller to turn on the LCD screen. The first screen you will see is the visual battery strength indicator (Fig. 13). After 5 seconds, this will default back to the Main Menu screen, where the following features can be found. Starting with the top feature:



BATTERY STRENGTH INDICATOR

Displays the current state of the batteries. The visual battery icon will appear “full” when batteries are still healthy. As the batteries drain, the battery icon will appear more and more depleted. The word next to the battery icon will give a quick synopsis of the battery strength (i.e. Healthy, Average, Poor Health). When the batteries have depleted to a point where they no longer can operate the solenoid, the battery strength indicator will read “REPLACE!” At this time, the controller will beep every time an object is sensed, but will not operate the solenoid. Replace the batteries immediately when this happens.



RUN-ON TIME

Water flow stops at the selected run-on time after the user removes hands from the sensing zone. Run-on selection times are 0 to 8 seconds or 1 to 8 minutes for scrub-up applications. Run time is factory set to 0 seconds. Note: If the user activates the faucet before the run time expires, the faucet will continue to operate and reset when their hands are removed again.



RESPONSE TIME

Response time is the amount of response time it takes for the sensor to react to hands placed in the sensing zone. The factory default is 4 pulses per second (Standard). This can be decreased to 2 pulses per second (Slow) to save battery life or increased to 8 pulses per second (Fast) for maximum response. Note: Using 8 pulses per second will significantly reduce battery life. This feature is most beneficial when the controller is hardwired.



BLOCK TIME (1-8 SECONDS)

The blocking time is the amount of time required between uses. This prevents the faucet from activating again until the blocking time has expired. The default value is 1 second. The blocking time moves up in 1-second increments, up to 8 seconds max.



SENSE RANGE (3" - 15")

The sensor range is the maximum distance at which the user is detected. The sensor range includes 3", 6", 8", 10", 12" and 15". The gooseneck product default value is 10". Note: Sensor ranges ± 1 " subject to environmental conditions.



METERING MODE

This allows for a continuous flow for a set amount of time, regardless of how long an object is placed in front of the sensor. Metered program is selectable from 7 to 240 seconds (when enabled) of continuous operation. It is factory set to Disabled.

ADDITIONAL FEATURES

Buzzer: Allows the user to turn ON or OFF the audible buzzer. Factory set to ON.

Language: Allows the user to set their desired language of the controller; either English or French. Factory set to English.

Diagnostics: Controller logs and displays Average usage per day, as well as Average Time-On of the faucet and Total Faucet Activations to Date.

Set Defaults: This option is found in the Diagnostics Menu. Selecting this feature resets all previously altered settings (i.e., Sense Time, Run-On Time) and sets them back to their initial default value.

Self-Test: Used to help troubleshoot the electronics. It helps test out the features of your electronic faucet - like the solenoid, sensor, 3-position switch feature and more.

After the settings are made place the cover back onto the box. If you have any questions about the installation of this product or need help trouble shooting this product, please call Delta Commercial Technical Services at 1-800-387-8277.

TROUBLE SHOOTING GUIDE

CONDITION 1: NO LIGHTS, NO POWER?	
CAUSE:	SOLUTION:
1A: Batteries are NOT installed, or are not installed properly.	1A: Ensure that each battery is installed properly. For correct orientation use the positive (+) and negative (-) markings and/or the battery shaped cutouts inside each cavity. Rotate each battery inside its cavity to establish better electrical contact.
1B: Batteries are low.	1B: Replace with 4 new "C" alkaline batteries. With initial power you will see the LCD screen turn on.
1C: Battery pack is not properly connected to the circuit board.	1C: Ensure that the wire between the battery pack and the controller is properly connected.
1D: Improper voltage on hardwire installation.	1D: Ensure that the voltage of the transformer is 24VAC and that it is attached to the 060683A conversion kit (see page 1).
1E: Controller assembly not functional.	1E: Replace controller assembly with 060989A.

CONDITION 2: POWER SUPPLY IS SUFFICIENT; HOWEVER, THERE IS NO WATER FLOW	
CAUSE:	SOLUTION:
2A: Water lines have been connected to the solenoid valve in reverse.	2A: Ensure that the water lines have been connected to the solenoid valve properly. Arrow marking on body (indicating water flow direction) must point to the spout.
2B: Black and red wires from controller box are not properly connected to the solenoid valve.	2B: Ensure that the black and red wires from the controller are connected to the proper terminals on the solenoid valve (red wire should be connected to solenoid terminal where there is "+" markings).
2C: Solenoid valve is not functional. It is not activating (no opening/closing "click").	2C: Replace solenoid valve with 060910A or 060671A.
2D: Solenoid strainer is blocked.	2D: Remove and clean solenoid strainer screen. Note: Solenoid strainer is located on the inlet side of the solenoid.
2E: Aerator is blocked.	2E: Remove and clean or replace aerator.
2F: Controller assembly is malfunctioning (not firing solenoid valve).	2F: Replace controller assembly with 060989A.

CARE INSTRUCTIONS

This Delta Commercial faucet is designed and engineered in accordance with the highest quality and performance standards. With proper care, it will give years of trouble free service. Care should be given to the cleaning of this product. Although the chrome finish is extremely durable, it can be **DAMAGED** by **ACIDIC CLEANERS** (i.e., cleaners designed specifically for vitreous lavatories and water closets), **HARSH ABRASIVES** or **POLISH**. To clean, simply wipe the surface with a damp cloth and blot dry with a soft cloth. Avoid directing water spray or cleaners directly at the sensor lens.

Delta Commercial Faucet Limited Warranty

All parts of the Delta® HDF® and TECK® faucets are warranted to the original consumer purchaser to be free from defects in material, finish and workmanship for a period of five (5) years unless otherwise specifically stated in the catalogue and price book. This warranty is made to the original consumer purchaser and shall be effective from date of purchase as shown on purchaser's receipt.

Delta will, at its option, repair or replace, FREE OF CHARGE, during the warranty period, any part which proves defective in material or workmanship under normal installation, use and water and service conditions. If Delta Faucet concludes that the returned part was manufactured by Delta Faucet and is, in fact, defective, then Delta Faucet will honour the warranty stated herein. Replacement parts can be obtained from your local dealer or distributor listed in the telephone directory or by returning the part along with the purchaser's receipt to our factory, TRANSPORTATION CHARGES PREPAID, at the address listed. THIS WARRANTY IS THE ONLY EXPRESS WARRANTY MADE BY DELTA. ANY CLAIMS MADE UNDER THIS WARRANTY MUST BE MADE DURING THE FIVE YEAR PERIOD REFERRED TO ABOVE. ANY IMPLIED WARRANTIES, INCLUDING THE IMPLIED WARRANTY OF MERCHANTABILITY OF FITNESS FOR A PARTICULAR PURPOSE, ARE LIMITED IN DURATION TO THE DURATION OF THIS WARRANTY. LABOUR CHARGES AND/OR DAMAGE INCURRED IN INSTALLATION, REPAIR OR REPLACEMENT AS WELL AS INCIDENTAL AND CONSEQUENTIAL, SPECIAL, INDIRECT OR PUNITIVE DAMAGES CONNECTED THEREWITH ARE EXCLUDED AND WILL NOT BE PAID BY DELTA FAUCET.

Some states do not allow limitations on how long an implied warranty lasts, or the exclusion or limitation of incidental or consequential damages, so the above limitations or exclusions may not apply to you. This warranty gives you specific legal rights, and you may also have other rights which vary from state to state.

This warranty is for commercial products only from Delta Faucet Company and Delta Faucet Canada (a division of Masco Canada Limited) and is void for any damage to this faucet due to misuse, abuse, neglect, accident, improper installation, any use in violation of instructions furnished by Delta Faucet or any use of replacement parts other than genuine Delta parts.

Garantie Limitée Delta Commercial

Toutes les pièces des robinets de marque Delta® HDF® et TECK® sont garanties contre tout défaut de matériel, de finition et de main-d'oeuvre pour une période de cinq (5) ans, sauf indication contraire stipulée dans le catalogue et la liste des prix. Cette garantie est offerte à l'acheteur original et entre en vigueur à compter de la date d'achat indiquée sur la preuve d'achat.

Delta procédera, à son entière discrétion, à la réparation ou au remplacement, SANS FRAIS, durant la période de garantie, de toute pièce qui présente un défaut de matériel ou de main-d'oeuvre dans des conditions d'installation, d'usure, d'eau et de service normales. Si Delta Faucet détermine que la pièce retournée a été fabriquée par Delta Faucet et qu'en effet, cette pièce défectueuse, Delta Faucet respectera alors la garantie mentionnée ci-dessous. Les pièces de rechange peuvent être obtenues chez votre marchand local ou le distributeur inscrit dans votre annuaire téléphonique, ou en retournant la pièce ainsi que la preuve d'achat à notre usine, FRAIS DE TRANSPORT PRÉPAYÉS, à l'adresse indiquée. CETTE GARANTIE EST LA SEULE GARANTIE EXPRESSE FAITE PAR DELTA.

TOUTE RÉCLAMATION FAITE EN VERTU DE CETTE GARANTIE DOIT ÊTRE PRÉSENTÉE DURANT LA PÉRIODE DE CINQ ANS MENTIONNÉE CI-DESSUS. TOUTE GARANTIE IMPLICITE, Y COMPRIS LA GARANTIE IMPLICITE DE VALEUR COMMERCIALE D'ADÉQUATION POUR UN USAGE PARTICULIER, EST LIIMITÉE DANS LE TEMPS À LA DURÉE DE LA PRÉSENTE GARANTIE.

LES FRAIS DE MAIN-D'OEUVRE ET/OU LES DOMMAGES ENCOURUS DURANT L'INSTALLATION, LA RÉPARATION OU LE REMPLACEMENT AINSI QUE LES DOMMAGES ACCIDENTELS ET CONSÉCUTIFS, SPÉCIAUX, INDIRECTS OU PUNITIFS QUI SONT RELIÉS SONT EXCLUS ET NE SERONT PAS PAYÉS PAR DELTA FAUCET.

Certains états ne permettent pas la limitation de la durée de la garantie implicite, ou l'exclusion ou la limitation des dommages accidentels ou consécutifs, et par conséquent, les limitations ou les exclusions stipulées ci-dessus peuvent ne pas s'appliquer dans votre cas. Cette garantie vous accorde certains droits reconnus par la loi et vous pouvez aussi avoir d'autres droits qui varient d'un état à l'autre.

Cette garantie s'applique seulement aux produits commerciaux de Delta Faucet Company et Delta Faucet Canada (une filiale de Masco Canada Limited) et est nulle de plein droit pour tout dommage causé à ce robinet en raison d'une mauvaise utilisation, d'abus, de négligence, d'accident, de mauvaise installation, pour tout usage en contravention des directives fournies par Delta Faucet ou pour tout usage de pièces de rechange autres que des pièces originales Delta.

Garantía Limitada de las Llaves de Agua Comerciales Delta

Todas las piezas de las llaves de agua (grifos) Delta® HDF®, TECK® están garantizadas al comprador consumidor original de estar libres de defectos de material, acabado y fabricación por un periodo de cinco (5) años a menos que sea establecido específicamente de otra manera en el catálogo o libro de precios. Esta garantía se le otorga al comprador consumidor original y será efectiva desde la fecha de compra indicada en el recibo del comprador.

Delta, a su opción, reparará o reemplazará, GRATUITAMENTE, durante el periodo de garantía, cualquier pieza que resulte defectuosa en material o fabricación bajo instalación, uso, agua y condiciones de servicio normales. Si Delta Faucet concluye que la pieza devuelta fue fabricada por Delta Faucet y es, de hecho, defectuosa, entonces Delta Faucet honrará la garantía establecida en este documento.

Las piezas de reemplazo se pueden obtener de su tienda o distribuidor local listado en la guía telefónica o devolviendo la pieza junto con el recibo de compra a nuestra fábrica, CON LOS GASTOS DE ENVÍO PRE-PAGADOS, a la dirección indicada. ESTA GARANTÍA ES LA ÚNICA GARANTÍA EXPRESA HECHA POR DELTA. CUALQUIER RECLAMO HECHO BAJO ESTA GARANTÍA DEBE SER HECHO DURANTE EL PERÍODO DE CINCO AÑOS ARRIBA MENCIONADO. CUALQUIER GARANTÍA IMPLÍCITA, INCLUYENDO LA GARANTÍA IMPLÍCITA DE COMERCIABILIDAD DE EMPLEO PARA UN PROPÓSITO PARTICULAR, TIENE UNA DURACIÓN LIMITADA A LA DURACIÓN DE ESTA GARANTÍA. LOS CARGOS DE MANO DE OBRA Y/O DAÑO INCURRIDO DURANTE LA INSTALACIÓN, REPARACIÓN O REEMPLAZO, COMO TAMBIÉN DAÑOS INCIDENTALES O RESULTANTES, ESPECIALES, INDIRECTOS O PUNITIVOS RELACIONADOS CON LO MENCIONADO, QUEDAN EXCLUIDOS Y NO SERÁN CUBIERTOS POR DELTA FAUCET.

Algunos estados no permiten limitaciones de la duración de una garantía implícita, o la exclusión o limitación de daños incidentales o consecuentes, de manera que las limitaciones o exclusiones arriba mencionadas puedan no aplicarse en su caso. Esta garantía le otorga derechos legales específicos, y usted también puede tener otros derechos que varían de estado a estado.

Esta garantía es solo para productos comerciales de Delta Faucet Company y Delta Faucet Canada (una división de Masco Canada Limited), y queda anulada por cualquier daño ocasionado a esta llave de agua resultante del mal uso, abuso, descuido, accidente, instalación incorrecta, cualquier uso en violación de las instrucciones proporcionadas por Delta Faucet o el uso de cualquier parte de repuesto que no sea una parte genuina de Delta.

Delta Faucet Canada, a division of Masco Canada Limited
350 South Edgeware Road, St. Thomas, Ontario, N5P 4L1
1-800-567-3300 (English) 1-800-265-9245 (French)

Delta Faucet Company
Box 40980, 55 East 111th St., Indianapolis, IN, U.S.A. 46280
(317) 848-1812

For further technical assistance, call Delta Commercial Technical Service at 1-800-387-8277.

Pour obtenir de l'assistance technique, appelez le Service Technique de Delta Commercial au 1-800-387-8277.

Por la asistencia técnica adicional, llame al servicio técnico de Delta Comercial al 1-800-387-8277.