



Electronic Concealed Flushvalve

160 __ T6 __ __ __ series
Write purchase model number here for future reference

210090

210090

210090

210090

210090

210090

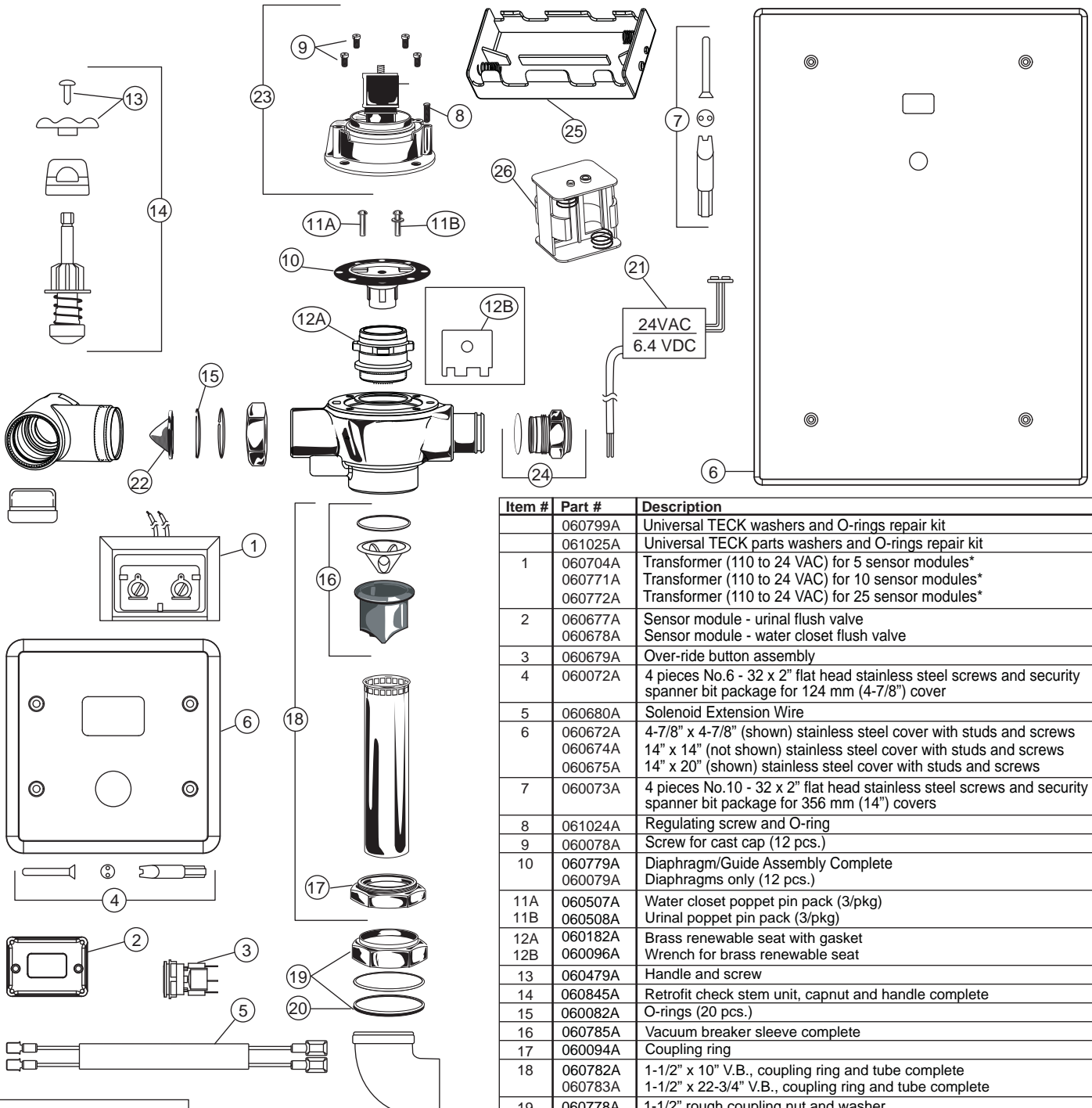

Item #	Part #	Description
	060799A	Universal TECK washers and O-rings repair kit
	061025A	Universal TECK parts washers and O-rings repair kit
1	060704A 060771A 060772A	Transformer (110 to 24 VAC) for 5 sensor modules* Transformer (110 to 24 VAC) for 10 sensor modules* Transformer (110 to 24 VAC) for 25 sensor modules*
2	060677A 060678A	Sensor module - urinal flush valve Sensor module - water closet flush valve
3	060679A	Over-ride button assembly
4	060072A	4 pieces No.6 - 32 x 2" flat head stainless steel screws and security spanner bit package for 124 mm (4-7/8") cover
5	060680A	Solenoid Extension Wire
6	060672A 060674A 060675A	4-7/8" x 4-7/8" (shown) stainless steel cover with studs and screws 14" x 14" (not shown) stainless steel cover with studs and screws 14" x 20" (shown) stainless steel cover with studs and screws
7	060073A	4 pieces No.10 - 32 x 2" flat head stainless steel screws and security spanner bit package for 356 mm (14") covers
8	061024A	Regulating screw and O-ring
9	060078A	Screw for cast cap (12 pcs.)
10	060779A 060079A	Diaphragm/Guide Assembly Complete Diaphragms only (12 pcs.)
11A	060507A	Water closet poppet pin pack (3/pkg)
11B	060508A	Urinal poppet pin pack (3/pkg)
12A	060182A	Brass renewable seat with gasket
12B	060096A	Wrench for brass renewable seat
13	060479A	Handle and screw
14	060845A	Retrofit check stem unit, capnut and handle complete
15	060082A	O-rings (20 pcs.)
16	060785A	Vacuum breaker sleeve complete
17	060094A	Coupling ring
18	060782A 060783A	1-1/2" x 10" V.B., coupling ring and tube complete 1-1/2" x 22-3/4" V.B., coupling ring and tube complete
19	060778A 060773A 060463A	1-1/2" rough coupling nut and washer 1-1/4" rough coupling nut and washer 3/4" polished chrome coupling nut, 3/4" washer and 3/4" spud flange
20	060083A 060049A	1-1/2" rubber slip joint washers (12 pcs.) 3/4" rubber and fibre slip joint washers (12 pcs.)
21	060683A	24VAC to 6VDC converter
22	060344A	Filter screen kit (12/pkg)
23	061022A	Electronic flush valve cap assembly with screws
24	060342A	Plug and O-ring for handle end
25	060681A	Flat battery holder (4 "C" cell batteries)
26	060684A	Square battery holder (4 "C" cell batteries)

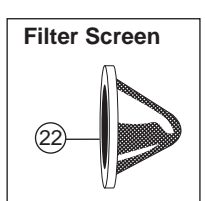
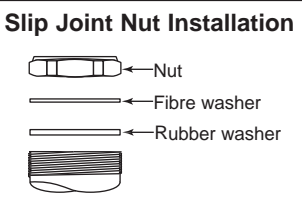

PLEASE LEAVE this sheet with the owner, maintenance plumber, etc. as items relating to ongoing maintenance suggestions and procedures are included.

NOTE: Refer to TECK flushometer repair parts and maintenance manual for additional parts and information.
*Each individual sensor module requires its own 24VAC to 6VDC hardwire converter.

ELECTRONIC FLUSH VALVE INSTALLATION INSTRUCTION

STEP 1 – ROUGH-IN FLUSH VALVE, FRAME OR BOX

NOTE: Due to excess back pressure of low flow water closets, outlet tubes must be braced to prevent tubes from disconnecting.

- Install and attach flush valve to water supply as per Fig. 1C.

INSTALL FILTER SCREEN (included) :

Note: Place filter in stop bore with conical screen facing the water flow.
Caution: Do not push filter in too far. Let filter seat against face of flush valve tail. Periodic cleaning of the filter screen with water is recommended depending on local water conditions to remove any dirt or sediment. See filter screen M&I for additional installation information.

4" Sensor Plate Models If Hardwire Operated

- 102 mm (4") box is supplied, remove suitable knockouts and insert cable bushing as per Fig. 1A.
- Rough-in box for sensor location as per Fig. 1D.
 Note: Solenoid extension cord supplied with the trim is 1,200 mm (48") long.
- Securely attach box to wall structure.
- Install CSA and/or UL approved Class 2 transformer or equivalent in a convenient location or in a pipe chase. **(Do NOT install the transformer inside the control box.)**
- Run suitable wire from 24VAC power source into box. Use wire which complies with local electrical codes for 1 amp load. No.18 cable is usually sufficient.
- Attach supplied plasterguard as per Fig. 1B to ensure sensor mounting holes are positioned correctly.

4" Sensor Plate Models If Battery Operated

- 102 mm (4") box and 4" box extension is supplied. Remove suitable knockout as per Fig. 1A.
- Attach box extension to front of the box.
- Rough-in box assembly for sensor location as per Fig. 1D.
 Note: Solenoid extension cord supplied with the trim is 1,220 mm (48") long.
- Securely attach box to wall structure.
- Attach supplied plasterguard as per Fig. 1B to ensure sensor mounting holes are positioned correctly.

14" and 14" X 20" Sensor Plate Models

- 12" or 12" x 18" frame is supplied. Rough in frame so the valve will be positioned as shown per Fig. 1D.
- Securely attach frame to wall structure.

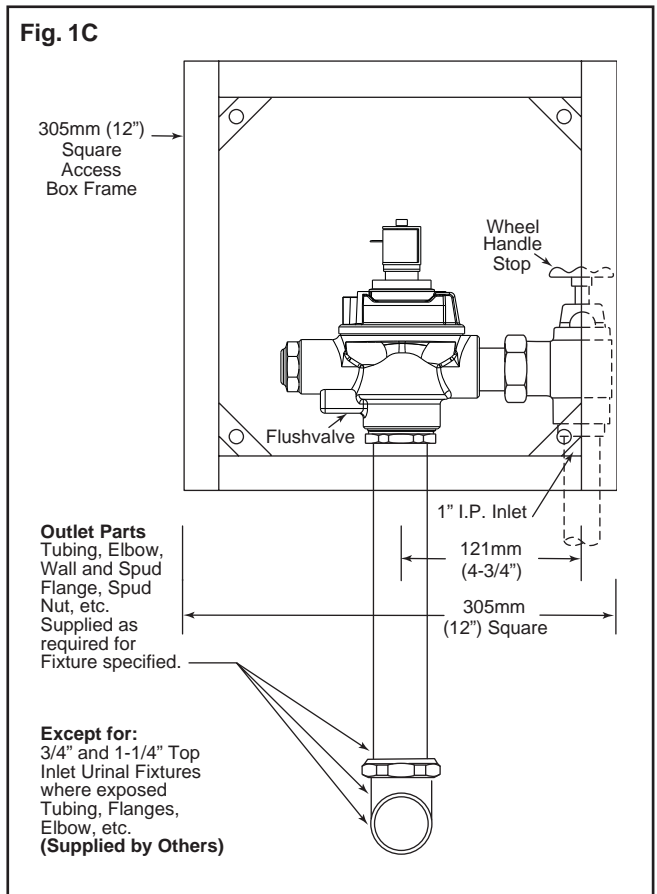
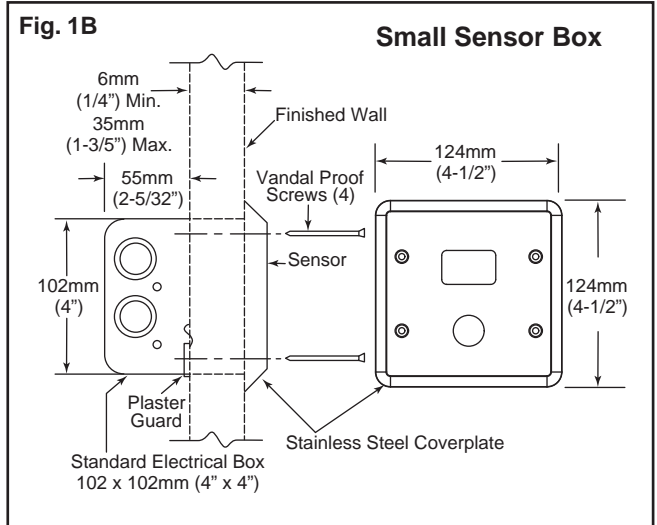
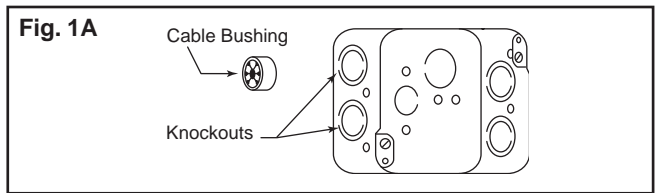
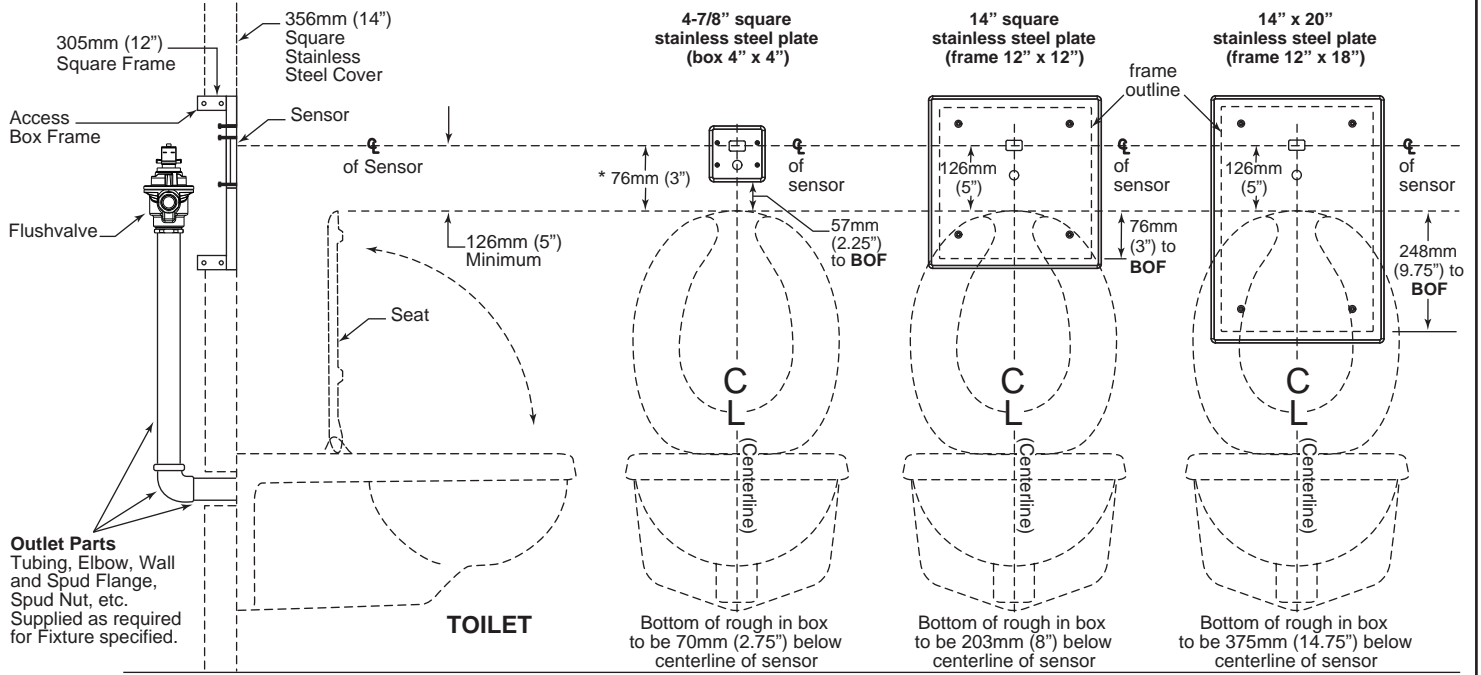

Fig. 1D

BOF = Bottom Of Frame



* NOTE: Recommended height to sensor from top of fixture is 508-559mm (20-22") with 610mm (24") maximum.

NOTE: Due to excess back pressure of low flow water closets, outlet tubes must be braced to prevent tubes from disconnecting.

BOF = Bottom Of Frame

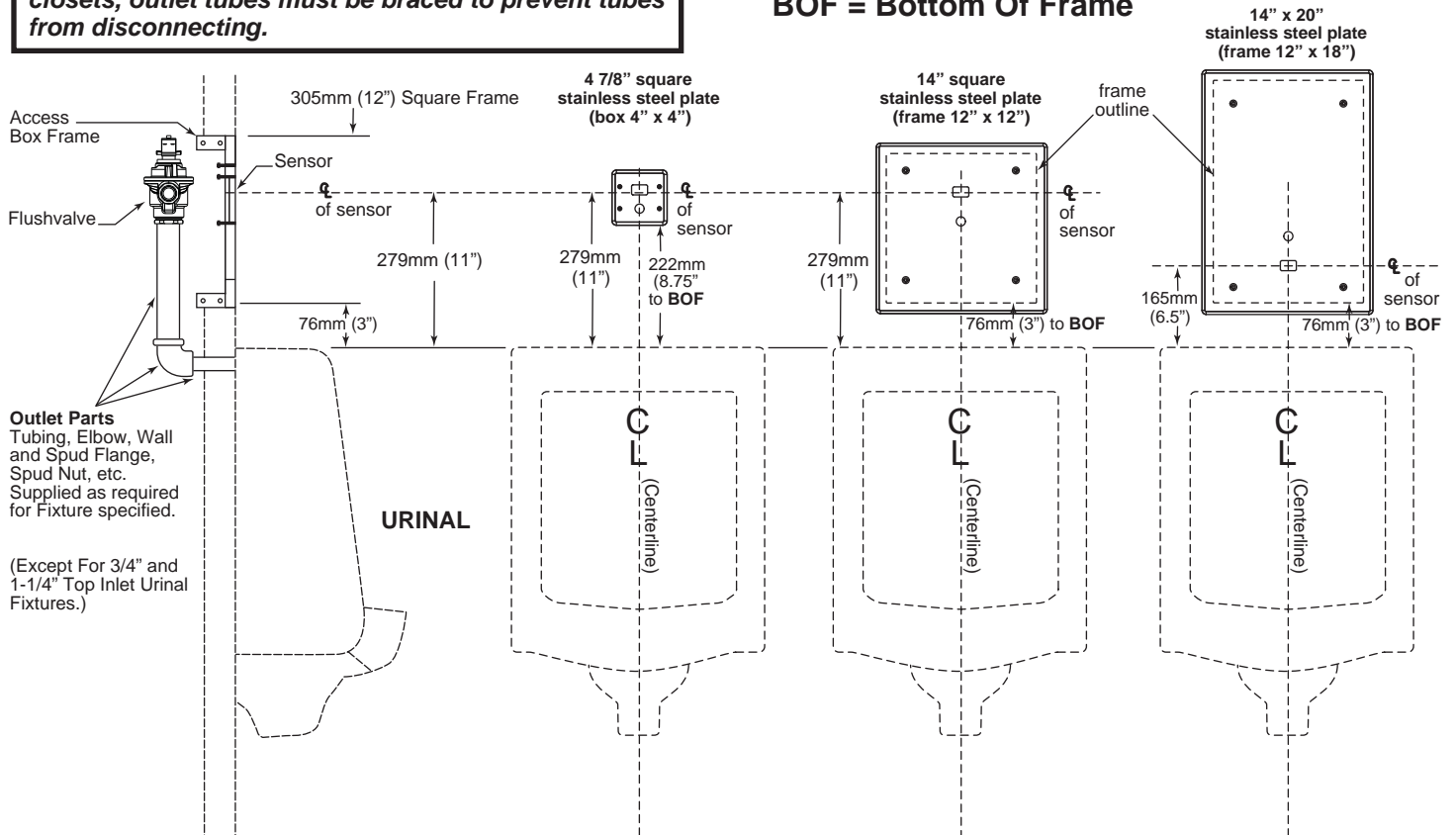

Product Supplied as Shown by Solid Lines.
All Items Shown by Dotted Lines Supplied by Others.

STEP 2 – INSTALL SENSOR PLATE

If Hardwire Operated

- Attach hardwire converter supplied to the 24VAC power source using the wire nuts provided.
- Attach converter to the sensor module using the snap connector.
With power to flushometer, there will be a sequence of red lights that strobe across the sensing lens window which signifies that the valve is now in operation mode.
- 4" Plate Models - Using the 1,220 mm (48") solenoid extension cord supplied, attach the male tabs to the sensor module and the female connectors to the solenoid on the flush valve. Make sure to correctly match the wire colours on the sensor module and on the solenoid. Red wire attaches to the positive (+) tab which is marked in red on the solenoid coil.
- 14" Plate Models - Connect the female connectors from the sensor module to the solenoid on the flush valve. Make sure to correctly match the wire colours on the sensor module to the solenoid. Red wire attaches to the positive (+) tab which is marked in red on the solenoid coil.
- If the factory default settings for the sensor are not suitable, refer to step 4 for sensor adjustments.
- Attach sensor plate to the box using the 4 vandalproof screws provided.

Fig. 2

Solenoid Extension Cord

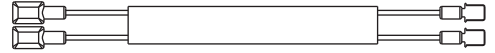

If Battery Operated

- Install 4 "C" cell batteries provided into the battery holder and attach the holder to the sensor module using the battery clip. Use the +/- on the battery holder for correct battery positioning. With power to flushometer, there will be a sequence of red lights that strobe across the sensing lens window which signifies that the valve is now in operation mode.
- 4" Plate Models - Using the 1,200 mm (48") solenoid extension cord supplied, attach the male tabs to the sensor module and the female connectors to the solenoid valve. Make sure to correctly match the wire colours on the sensor module and on the solenoid. Red wire attaches to the positive (+) tab which is marked in red on the solenoid coil.
- 14" Plate Models - Connect the female connectors from the sensor module to the solenoid on the flush valve. Make sure to correctly match the wire colours on the sensor module to the solenoid. Red wire attaches to the positive (+) tab which is marked in red on the solenoid coil.
- If the factory default settings for the sensor are not suitable, refer to step 4 for sensor adjustments.
- 4" Plate Models - Install battery holder into the back of the box and attach the sensor plate to the box using the 4 vandalproof screws provided.
- 14" Plate Models - Attach battery holder with the 2 way tape provided, to a secure location on the wall framing, etc.

STEP 3: OPERATION MODE

A sequence of red lights that strobe across the sensing lens window will signify that the valve is now in operation mode.

Once in operation mode, if factory settings are preferred, no further action is required and the valve installation is complete.

Factory pre-set functions are:

Water closet sensing distance of 40", 24 hour flush is off, and flush delay is 4 seconds.
Urinal sensing distance of 20", 24 hour flush is on, and no flush delay.

Once in operation mode, if adjustments are preferred, installer must move into set up mode.

FUNCTION AND TROUBLESHOOTING LIGHTS

BATTERY VERSION: NO LIGHTS-NO POWER

Check that the 4 "C" batteries are positioned properly in the battery holder. Use the +/- on the battery holder for correct positioning. If the batteries are positioned correctly but there are still no lights, replace with 4 new "C" Alkaline batteries.*

HARDWARE VERSION: NO LIGHTS-NO POWER

Check that the 24VAC transformer has power on the incoming 120VAC side. (Transformer breaker is turned on.)

Check the connection of the flushometer wires to 24VAC transformer.

Check that the connection of the hardwire converter is made to the electronic board within the electronic flush valve housing.

For further technical assistance, call Delta Commercial Technical Service at 1-800-387-8277.

1. **Start-Up:** When batteries are first inserted, a sequence of red lights that strobe across the sensing lens window will signify that the valve is now in operation mode.
2. **Override Button in Operating Mode:** BLUE light flashes once when Override Button is activated. Should the manual override button stick, the program will continue to operate and will reset automatically if the override button is repaired or it returns to home position.
3. **Battery Level Indicator:** RED light flashes every 3 seconds, indicating approximately 5,000 flushes remain from when RED light first started flashing.
4. **Checking Battery Strength:** In operation mode, it is possible to check the strength of the batteries by holding down the override button until the RED lights begin to flash. The strength of the batteries is proportional to the number of lights that are displayed when the override button is held down. For example, 5 RED lights signify full battery strength; while 1 RED light indicates very weak battery strength (replace batteries when this occurs).

***Note: All original settings will be retained when batteries are changed.**

STEP 4: MAKING ADJUSTMENTS

(Optional: Only required if factory settings are not preferred.)

- To move from operation mode into set-up mode: remove the plastic plug located in the rear of the sensor module and press the set-up mode button once. A pencil or small screwdriver may be required. When done, place the plug back in the hole.

4.1 Adjusting Sensing Distances:

- Sequences of red lights will intermittently strobe across the sensor window, followed by a number of red lights which stay on to indicate the current sensing distance.

Pre-set sensing distances are:

Water Closet		Urinal	
1 light	24"	1 light	12"
2 lights	32"	2 lights	16"
3 lights	40" (factory set)	3 lights	20" (factory set)
4 lights	48"	4 lights	24"
5 lights	56"	5 lights	28"

- A pulsating blue light on the far left of the sensor window will indicate if an object is detected. However, the sensing distance could be set at a distance greater or shorter than the desired activating position.
- To ensure sensing distance is set to precise desired position, stand at desired activating distance.
- If the pulsating blue light is not present, press the override button (the red lights will increment).
- Continuing to press the override button will eventually loop the sensing distance back to 1 light (12" sensing distance for Urinal, 24" sensing distance for water closet).
- Press override button until pulsating blue light is present. The blue light indicates that the sensing distance has been adjusted to a position that is detecting you.

Water closet only:

- Now stand back and ensure that the pulsating blue light disappears when you stand near the door of the water closet.
- Ensure that the door is not being detected as well. If so, decrease the range increment by 1 light (this is achieved by pressing the override button until the lights loop back around to a setting that is one less the previous setting).
- Once again, verify that the sensor is not detecting the water closet door. If not, the sensor is now set at your desired position.
- The sensing distance for water closets can be set between 24" and 56", and for urinals between 12" and 28".
- If all adjustments have been completed, press and hold down the manual override button for 5 seconds. For water closets, this will return the valve to operation mode. For urinals, this will advance the distance adjustment mode into the 24 Hour Flush adjustment mode.

4.2 Adjusting 24 Hour Flush (for Urinal applications):

- When 3 red lights in the centre of the sensor window are on, 24 hour flush is on.
- When the red light in the middle of the 3 lights is off, the 24 hour flush is off.
- Press manual override button to toggle between on and off mode.
- If all adjustments have been completed, press and hold down the manual override button for 5 seconds until all lights go out.

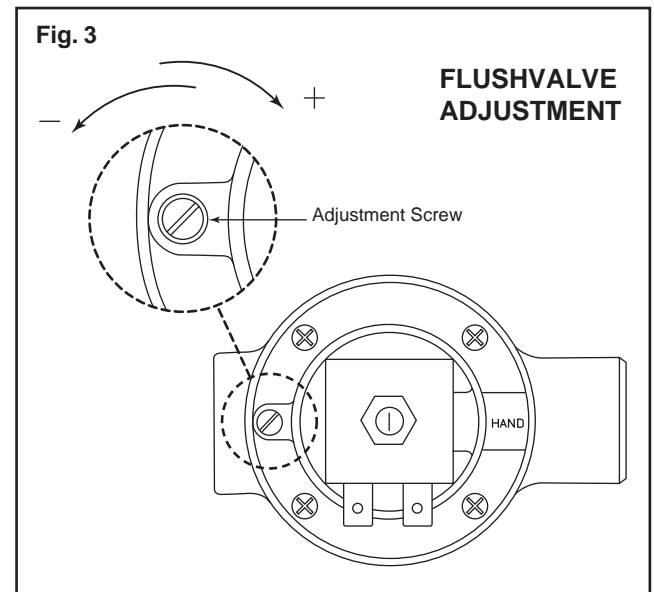

PROBLEM SOLVING & MAINTENANCE SUGGESTIONS:

NOTE: DO NOT USE EXCESSIVE FORCE to close the inlet stop stem. We RECOMMEND that the flushometer be flushed while closing the inlet stop. The noise created by the water flow or the flow into the fixture will stop when the inlet water is shut off.

NOTE: Always use DELTA COMMERCIAL GENUINE PARTS to maintain the warranty.

EXCESSIVE NOISE:

1. PARTIALLY close the inlet stop.
2. Pressures OVER 75 PSI may lead to an increase in NOISE, water could SPLASH out of the fixture more easily and the LIFE of any plumbing valve may be SHORTENED.
3. INSTALL a Pressure Reducing Valve set at a lower pressure if actual pressure is over 75 PSI. While the TECK Flushometer will operate up to 125 PSI, the preferred operating range is between 35 to 65 PSI.
4. On flushometers that have been installed for a number of years, check the Renewable Seat (060182A, item #12A) for wear and replace if necessary.

EXCESSIVE WATER FLOW RATE:

1. OPEN inlet stop ONE TURN and adjust Regulating Screw (060786A, item #8) to the fixture requirement (except on -6 and -48 models which are fixed volume).
2. Operation of flushometer with inlet stop BELOW ONE TURN OPEN may cause EXCESSIVE NOISE. The lowest open setting for the inlet stop may vary dependent on the installation.

SHORTAGE OF WATER TO PROPERLY FLUSH BOWL:

1. OPEN inlet stop fully.
2. CHECK pipeline for size or obstruction, partially closed gate or other supply line valve, corroded or undersize water piping.
3. CHECK water pressure.
4. Water flow rate is determined by BOTH the water pipe size AND the water pressure available.
5. A water closet flush valve requires a minimum water supply of 1" (or larger), depending on a number of different factors including water pressure (PSI) available, pipe size and length of pipe run, number of fixtures per washroom and per building, fixture type, fixture usage factor, elevation of valve above the water main, etc. We strongly recommend that pipe size calculations be done to insure proper water supply sizes. A Piping Calculation Guide is available on request.

Flushometers do NOT provide a water supply; they are merely automatically timed self-closing valves. The inlet supply piping is the water reservoir that must supply sufficient water volume in a short period of time (4 to 10 seconds) to properly flush and clear the fixture.

CONTINUOUS FLUSHING:

1. The Regulating Screw (061024A, item #8) may be turned RIGHT (clockwise) TOO FAR. Adjust by slowly turning the Regulating Screw LEFT (counter-clockwise) (except -6 and -48 models which are fixed volume).
2. If flush is still continuous, remove 061024A Regulating Screw, CLEAN bypass slot in the Screw, REPLACE it in the valve and ADJUST slowly for proper flush (except -6 and -48 models which are fixed volume).
3. Remove cast cap assembly and Diaphragm/Guide Assembly (060779A, item #10), check for contaminants at renewable seat and diaphragm and check for debris in the cap for blockage. Also CHECK that the Diaphragm/Guide slides easily in the Renewable Seat.
4. After replacing the Diaphragm, be sure the sintered bronze Valve Silencer and the flat, white Plastic Washer are correctly aligned with the Cast Guide and do not catch on the top of the Renewable Seat (060182A, item #12A). To assure PROPER ALIGNMENT, slide the Diaphragm/Guide Assembly (060779A, item #10) into the Renewable Seat until the Diaphragm/Guide slides and seats smoothly and easily.

VALVE WILL NOT FLUSH:

1. When the valve has been taken apart for servicing and re-assembled and does NOT operate, check that the Cast Cap has been put on the body properly. The Regulating Screw (061024A, item #8) should always be on the same side as the inlet stop.
2. When all lights operate as expected but valve will not flush, check that the solenoid makes a clicking sound. If no clicking sound is present, then replace with Cap Assembly (061022A, item #23).
3. After a number of years, the valve will flush but shuts off immediately when activated. The Diaphragm (060779A, item #10) is worn or split and needs replacing.

SLIGHT WATER LEAK INTO FIXTURE:

1. EXAMINE the seating surface of the Diaphragm Seat (060779A, item #10) for imbedded sediment.

CLEANING INSTRUCTIONS:

CLEAN the outside of the chrome plated flushometer with a damp cloth.

CAUTION: MOST Tub & Tile fixture cleaners contain ACIDS. DO NOT WIPE the cloth used to clean ceramic fixtures over the flushometer as it will remove the chrome plating and leave a discoloured surface.

For a copy of the "TECK Flushometer Maintenance Manual/Piping Calculation Guide", contact your local Delta Representative.

Delta Commercial Faucet Limited Warranty

All parts of the Delta® HDF® and TECK® faucets are warranted to the original consumer purchaser to be free from defects in material, finish and workmanship for a period of five (5) years unless otherwise specifically stated in the catalogue and price book. This warranty is made to the original consumer purchaser and shall be effective from date of purchase as shown on purchaser's receipt.

Delta will, at its option, repair or replace, FREE OF CHARGE, during the warranty period, any part which proves defective in material or workmanship under normal installation, use and water and service conditions. If Delta Faucet concludes that the returned part was manufactured by Delta Faucet and is, in fact, defective, then Delta Faucet will honour the warranty stated herein. Replacement parts can be obtained from your local dealer or distributor listed in the telephone directory or by returning the part along with the purchaser's receipt to our factory, TRANSPORTATION CHARGES PREPAID, at the address listed. THIS WARRANTY IS THE ONLY EXPRESS WARRANTY MADE BY DELTA. ANY CLAIMS MADE UNDER THIS WARRANTY MUST BE MADE DURING THE FIVE YEAR PERIOD REFERRED TO ABOVE. ANY IMPLIED WARRANTIES, INCLUDING THE IMPLIED WARRANTY OF MERCHANTABILITY OF FITNESS FOR A PARTICULAR PURPOSE, ARE LIMITED IN DURATION TO THE DURATION OF THIS WARRANTY. LABOUR CHARGES AND/OR DAMAGE INCURRED IN INSTALLATION, REPAIR OR REPLACEMENT AS WELL AS INCIDENTAL AND CONSEQUENTIAL, SPECIAL, INDIRECT OR PUNITIVE DAMAGES CONNECTED THEREWITH ARE EXCLUDED AND WILL NOT BE PAID BY DELTA FAUCET.

Some states do not allow limitations on how long an implied warranty lasts, or the exclusion or limitation of incidental or consequential damages, so the above limitations or exclusions may not apply to you. This warranty gives you specific legal rights, and you may also have other rights which vary from state to state.

This warranty is for commercial products only from Delta Faucet Company and Delta Faucet Canada (a division of Masco Canada Limited) and is void for any damage to this faucet due to misuse, abuse, neglect, accident, improper installation, any use in violation of instructions furnished by Delta Faucet or any use of replacement parts other than genuine Delta parts.

Garantie Limitée Delta Commercial

Toutes les pièces des robinets de marque Delta® HDF® et TECK® sont garanties contre tout défaut de matériel, de finition et de main-d'oeuvre pour une période de cinq (5) ans, sauf indication contraire stipulée dans le catalogue et la liste des prix. Cette garantie est offerte à l'acheteur original et entre en vigueur à compter de la date d'achat indiquée sur la preuve d'achat.

Delta procédera, à son entière discrétion, à la réparation ou au remplacement, SANS FRAIS, durant la période de garantie, de toute pièce qui présente un défaut de matériel ou de main-d'oeuvre dans des conditions d'installation, d'usure, d'eau et de service normales. Si Delta Faucet détermine que la pièce retournée a été fabriquée par Delta Faucet et qu'en effet, cette pièce défectueuse, Delta Faucet respectera alors la garantie mentionnée ci-dessous. Les pièces de rechange peuvent être obtenues chez votre marchand local ou le distributeur inscrit dans votre annuaire téléphonique, ou en retournant la pièce ainsi que la preuve d'achat à notre usine, FRAIS DE TRANSPORT PRÉPAYÉS, à l'adresse indiquée. CETTE GARANTIE EST LA SEULE GARANTIE EXPRESSE FAITE PAR DELTA.

TOUTE RÉCLAMATION FAITE EN VERTU DE CETTE GARANTIE DOIT ÊTRE PRÉSENTÉE DURANT LA PÉRIODE DE CINQ ANS MENTIONNÉE CI-DESSUS. TOUTE GARANTIE IMPLICITE, Y COMPRIS LA GARANTIE IMPLICITE DE VALEUR COMMERCIALE D'ADÉQUATION POUR UN USAGE PARTICULIER, EST LIMITÉE DANS LE TEMPS À LA DURÉE DE LA PRÉSENTE GARANTIE.

LES FRAIS DE MAIN-D'OEUVRE ET/OU LES DOMMAGES ENCOURUS DURANT L'INSTALLATION, LA RÉPARATION OU LE REMPLACEMENT AINSI QUE LES DOMMAGES ACCIDENTELS ET CONSÉCUTIFS, SPÉCIAUX, INDIRECTS OU PUNITIFS QUI SONT RELIÉS SONT EXCLUS ET NE SERONT PAS PAYÉS PAR DELTA FAUCET.

Certains états ne permettent pas la limitation de la durée de la garantie implicite, ou l'exclusion ou la limitation des dommages accidentels ou consécutifs, et par conséquent, les limitations ou les exclusions stipulées ci-dessus peuvent ne pas s'appliquer dans votre cas. Cette garantie vous accorde certains droits reconnus par la loi et vous pouvez aussi avoir d'autres droits qui varient d'un état à l'autre.

Cette garantie s'applique seulement aux produits commerciaux de Delta Faucet Company et Delta Faucet Canada (une filiale de Masco Canada Limited) et est nulle de plein droit pour tout dommage causé à ce robinet en raison d'une mauvaise utilisation, d'abus, de négligence, d'accident, de mauvaise installation, pour tout usage en contravention des directives fournies par Delta Faucet ou pour tout usage de pièces de rechange autres que des pièces originales Delta.

Garantía Limitada de las Llaves de Agua Comerciales Delta

Todas las piezas de las llaves de agua (grifos) Delta® HDF®, TECK® están garantizadas al comprador consumidor original de estar libres de defectos de material, acabado y fabricación por un periodo de cinco (5) años a menos que sea establecido específicamente de otra manera en el catálogo o libro de precios. Esta garantía se le otorga al comprador consumidor original y será efectiva desde la fecha de compra indicada en el recibo del comprador.

Delta, a su opción, reparará o reemplazará, GRATUITAMENTE, durante el periodo de garantía, cualquier pieza que resulte defectuosa en material o fabricación bajo instalación, uso, agua y condiciones de servicio normales. Si Delta Faucet concluye que la pieza devuelta fue fabricada por Delta Faucet y es, de hecho, defectuosa, entonces Delta Faucet honrará la garantía establecida en este documento.

Las piezas de reemplazo se pueden obtener de su tienda o distribuidor local listado en la guía telefónica o devolviendo la pieza junto con el recibo de compra a nuestra fábrica, CON LOS GASTOS DE ENVÍO PRE-PAGADOS, a la dirección indicada. ESTA GARANTÍA ES LA ÚNICA GARANTÍA EXPRESA HECHA POR DELTA. CUALQUIER RECLAMO HECHO BAJO ESTA GARANTÍA DEBE SER HECHO DURANTE EL PERÍODO DE CINCO AÑOS ARRIBA MENCIONADO. CUALQUIER GARANTÍA IMPLÍCITA, INCLUYENDO LA GARANTÍA IMPLÍCITA DE COMERCIABILIDAD DE EMPLEO PARA UN PROPÓSITO PARTICULAR, TIENE UNA DURACIÓN LIMITADA A LA DURACIÓN DE ESTA GARANTÍA. LOS CARGOS DE MANO DE OBRA Y/O DAÑO INCURRIDO DURANTE LA INSTALACIÓN, REPARACIÓN O REEMPLAZO, COMO TAMBIÉN DAÑOS INCIDENTALES O RESULTANTES, ESPECIALES, INDIRECTOS O PUNITIVOS RELACIONADOS CON LO MENCIONADO, QUEDAN EXCLUIDOS Y NO SERÁN CUBIERTOS POR DELTA FAUCET.

Algunos estados no permiten limitaciones de la duración de una garantía implícita, o la exclusión o limitación de daños incidentales o consecuentes, de manera que las limitaciones o exclusiones arriba mencionadas puedan no aplicarse en su caso. Esta garantía le otorga derechos legales específicos, y usted también puede tener otros derechos que varían de estado a estado.

Esta garantía es solo para productos comerciales de Delta Faucet Company y Delta Faucet Canada (una división de Masco Canada Limited), y queda anulada por cualquier daño ocasionado a esta llave de agua resultante del mal uso, abuso, descuido, accidente, instalación incorrecta, cualquier uso en violación de las instrucciones proporcionadas por Delta Faucet o el uso de cualquier parte de repuesto que no sea una parte genuina de Delta.

Delta Faucet Canada, a division of Masco Canada Limited
25 South Edgeware Road, St. Thomas, Ontario, N5P 4L1
1-800-567-3300 (English) 1-800-265-9245 (French)

Delta Faucet Company
Box 40980, 55 East 111th St., Indianapolis, IN, U.S.A. 46280
(317) 848-1812

For further technical assistance, call Delta Commercial Technical Service at 1-800-387-8277.

Pour obtenir de l'assistance technique, appelez le Service Technique de Delta Commercial au 1-800-387-8277.

Por la asistencia técnica adicional, llame al servicio técnico de Delta Comercial al 1-800-387-8277.